

DNX408^{V2}

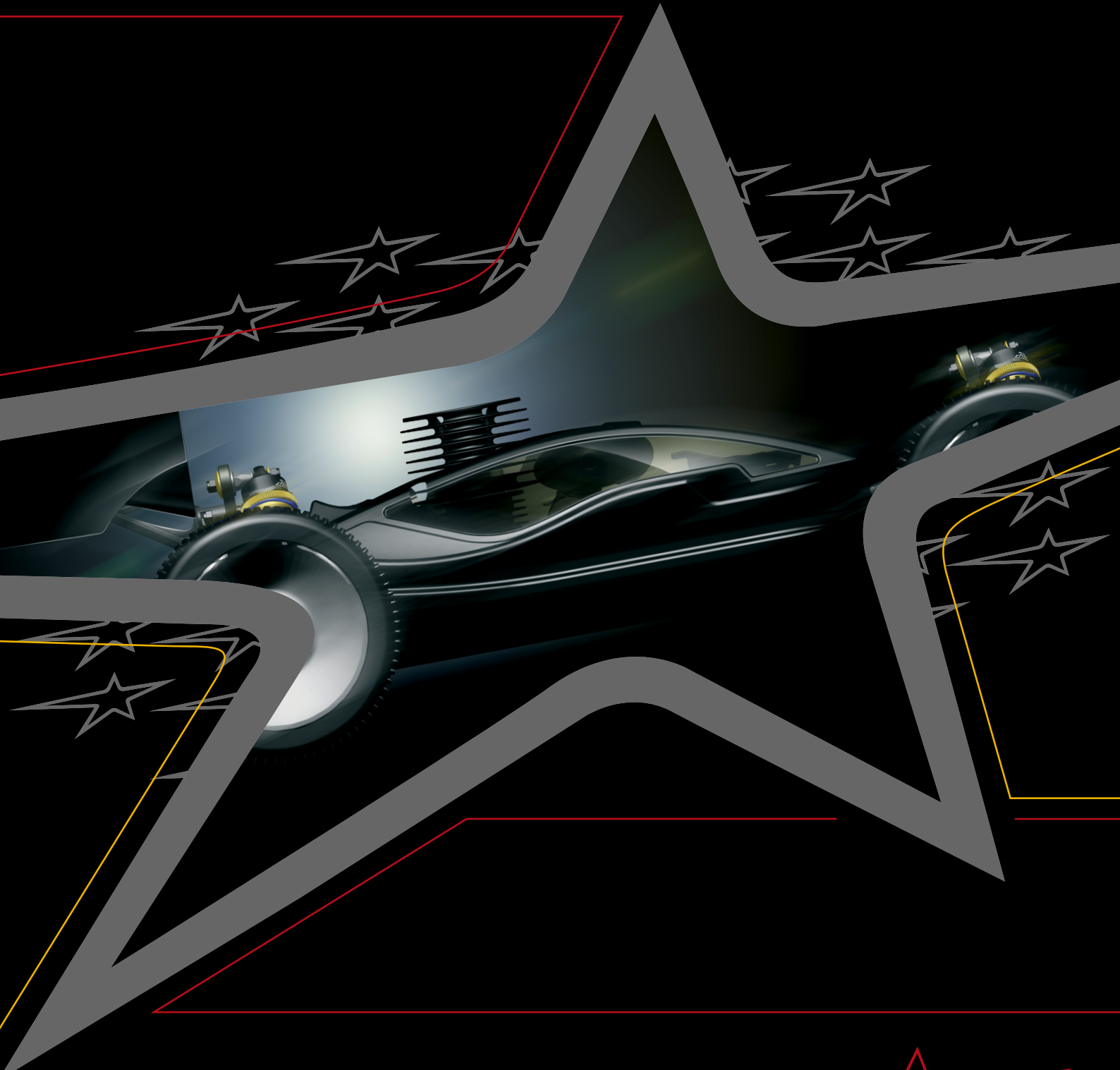

Team
durango
SERIOUS ABOUT RACING

Contents

Congratulations	.3.
Introduction	.3.
Before you begin	.4.
Assembly	.5.
Safety Notes – IMPORTANT	.6.
Symbol Reference Key	.8.
Assembly Instructions	.10.
Setup Sheet	.36.
Exploded View	.38.
Parts List - Standard Parts	.40.
Parts List - Option Parts	.41.
Team Durango Ltd	.43.

Inhaltsverzeichnis

Herzlichen Glückwunsch	.3.
Einführung	.3.
Bevor Sie anfangen	.4.
Zusammenbau	.5.
Sicherheitswarnungen – WICHTIG	.6.
Symbol Schlüssel	.8.
Montage Anleitung	.10.
Setup Sheet	.36.
Explosionsansicht	.38.
Ersatzteilleiste	.40.
Tuningteilleiste	.41.
Team Durango Ltd	.43.

目次

Congratulations	.3.
イントロダクション	.3.
はじめに	.4.
組立て前に	.5.
安全のために –重要！	.6.
シンボルリファレンス	.8.
組立て	.10.
Setup Sheet	.36.
展開図	.38.
パーツリスト	.40.
オプションパーツリスト	.41.
Team Durango Ltd	.43.

目錄

欢迎您的加入	.3.
产品介绍	.3.
组装前说明	.4.
组装	.5.
安全须知-重要！	.6.
说明书符号说明	.8.
组装步骤	.10.
Setup Sheeet	.36.
爆炸图	.38.
一般件零件表	.40.
改装件零件表	.41.
Team Durango 联络信息	.43.

Congratulations Herzlichen Glückwunsch 欢迎您的加入

Congratulations on purchasing your new DNX408 from Team Durango! You are clearly serious about racing - serious about winning!

Herzlichen Glückwunsch zum Kauf Ihres neuen DNX408 von Team Durango! Sie meinen es eindeutig ernst mit Racing – ernst mit dem Gewinnen!

Team Durango DNX408 バギーのご購入おめでとうございます！

恭喜您成为TEAM DURANGO DNX408的车主团队-对竞速与胜利有强烈执着的人们。

SERIOUS ABOUT RACING

Introduction Einführung イントロダクション 产品介绍

The DNX408 was designed in Germany, and tested by some of the world's best R/C racers.

Der in Deutschland konstruierte DNX408 wurde von einigen der weltbesten RC-Car Fahrern getestet.

DNX408はドイツでデザインされ、世界でもトップクラスのR/Cドライバーによりテストされました。

DNX408是经过德国顶级设计团队专门打造，且由全球顶尖车手多次测试验证的顶级赛车。

Introduction Einführung イントロダクション 产品介绍

Team Durango have spent the past year developing the DNX408. The ultimate 1/8 scale Nitro off-road racing buggy, the DNX408 uses Team Durango's championship-winning innovation, precision engineering and uncompromisingly bring you standard features like:

- Alloy bulkheads and shock mounts
- Revolutionary disk brake system
- Adjustable chassis-flex system
- Quick-release differentials
- Ultra-low Centre Of Gravity
- Memory engine mount
- Ultra-slim chassis design
- Vented receiver box
- Quick-release radio plate

If you are 'Serious About Racing', then you have the right car – Team Durango DNX408

Team Durango ha empleado el último año en desarrollar el DNX408. El DNX408 es el 1/8 todo terreno gas de competición definitivo, construido con una tecnología innovadora vencedora en competición, ingeniería precisa, y un diseño sin concesiones que ofrece como estándar las siguientes características:

- Manguetas y soportes de amortiguador de aleación
- Revolucionario sistema de freno de disco
- Chasis de flexibilidad ajustable con el sistema "chassis-flex"
- Diferenciales de extracción rápida
- Centro de gravedad ultra-bajo
- Memoria de posición de montaje del motor
- Chasis con diseño ultra-estrecho
- Caja de receptor ventilada
- Bandeja de radio de extracción rápida

Si para usted 'Serious About Racing', entonces tiene el coche adecuado - Team Durango DNX408

Team Durango a développé le DNX408 durant l'année écoulée. Buggy tout terrain 1/8ème ultime dédié à la compétition, le DNX408 utilise les innovations Team Durango, acquises en gagnant des compétitions. Une conception précise et sans compromis pour vous apporter les standards suivants :

- Cellules et supports d'amortisseurs en alliage
- Système de frein à disque révolutionnaire
- Démontage rapide de différentiel
- Un centre de gravité surbaissé
- Un support moteur à mémoire

- Une conception de châssis très étroit
 - Une boîte de récepteur ventilée
 - Un support d'électronique à démontage rapide
- Si vous êtes un 'Serious About Racing', vous avez la voiture adaptée, Team Durango DNX 408*

Team Durango 開発チームはDNX408の開発に長い時間を費やしました。この究極の1/8スケールオフロードマシンはTeam Durangoの「レースで勝利する為のマシン作り」、「精密なエンジニアリング」、「妥協なきデザイン」の信念に基づき生まれ、以下のような特徴を持ちます。

- アルミバルクヘッド・ショックマウント
- 革新的なディスクブレーキシステム
- アジャスタブル“シャーシフレックス”システム
- クイックリリースデフ
- 超低重心
- メモリーエンジンマウント
- “ウルトラスリム”シャーシデザイン
- ベンテッドレシーバーボックス
- “クイックリリース”ラジオプレート

Nach einem Jahr Entwicklungszeit konnte nun der Team Durango DNX408 fertig gestellt werden. Der ultimative 1:8 Nitro Off Road Buggy DNX408 mit den legendären Genen aus Innovation, Präzision und dem kompromisslosen Design von Team Durangos Ingenieuren beinhaltet serienmäßig Features, wie:

- Aluminium Bulkheads und Stoßdämpferbrücken
- Revolutionäres Bremssystem
- Einstellbares Chassis-Flex-System
- Schnellverschluss Differential Zugang
- Ultra-niedriger Chassis-Schwerpunkt
- Memory Engine Mount System
- Superschmales Chassis-Design
- Belüftete Empfängerbox
- Radioplatten-Schnellwechsel-System

Wenn du ist 'Serious About Racing', dann ist dies das richtige Fahrzeug für dich - Team Durango DNX408

DNX408是Team Durango在过去一年多致力研發之另一心血傑作。

DNX408出自Team Durango一贯的设计理念；以夺标為本之嶄新概念，配合精密造工及独一无二的设计而成之终极1/8四驱油越。

DNX408的标准装备如下：

- 铝合金波箱及油压架
- 革命性的碟刹制动系统
- 可调式车架屈动系统
- 快拆差速
- 超低重心设计
- 记忆式发动机座
- 超窄车身
- 散热式接收箱
- 快拆遥控设备架

对于认真竞赛之人仕，Team Durango DNX408一定是必然之选！

Before you begin Bevor Sie anfangen はじめに 組立前説明

This manual contains detailed step-by-step instructions to show you how to assemble and set-up your new DNX408 for optimum performance. We want you to get the most out of your new racing machine, so we suggest that you read this manual through, from cover to cover, before beginning assembly. All Team Durango products are manufactured to the highest possible standards, so should you find any parts difficult to assemble, please check that you are assembling them correctly.

If you don't follow these instructions exactly, you may damage parts of your DNX408.

If, for any reason, you decide that you do not want your DNX408, **you must not begin assembly.** Your DNX408 cannot be returned to your Team Durango dealer for a refund or exchange if it has been fully or partially assembled.

Diese Bauanleitung beinhaltet detaillierte Step by Step Anweisungen, die Ihnen zeigen, wie Sie Ihren neuen DNX408 zusammenbauen und einstellen müssen, um die optimale Leistung zu erreichen. Wir möchten, dass Sie das Maximum aus Ihrer neuen Renn-Maschine herausholen können und bitten Sie, diese Bauanleitung vorn bis hinten durchzulesen, bevor Sie mit dem Zusammenbau beginnen. Alle Team Durango Produkte

werden in den höchstmöglichen Standards produziert. Sollten Sie ein schwierig zu montierendes Bauteil finden, prüfen Sie bitte, ob es sich um das richtige Teil handelt und ob Sie es richtig montiert haben. Wenn Sie Ihr Fahrzeug nicht nach der Bauanleitung zusammenbauen, könnten Sie Ihren DNX408

beschädigen.

Wenn Sie aus bestimmten Gründen Ihren DNX408 nicht haben wollen, müssen Sie ihn nicht zusammenbauen. Ihr DNX408 kann nicht von Ihrem Team Durango Händler zurück genommen werden, wenn das Fahrzeug ganz, oder auch teilweise montiert wurde.

このマニュアルではDNX408の組立てに必要な説明をステップバイステップで行い、更に最高のパフォーマンスを引き出す組立方法を記載しています。本製品はこれまでのレーシングマシンとは一線を画す全く新しいマシンですので、組立前に本マニュアルを全ページ読まれる事をお薦めします。Team Durangoの全てのマシンは高い品質管理の元に製造されている為、万一組立の際にうまく組付けが出来ない場合には説明書通りの手順で組立てられているか確認してください。

本説明書通りに組付けを行わなかった場合、DNX408のパーツを破損する恐れがあります。

万一、何らかの理由でDNX408を返品される場合には組立を始めないでください。DNX408はその全部又は一部でも組立てられていると返金・交換には一切応じられませんのでご注意ください。

本说明书有详细的组装与调校教学，您可依照说明书的教学，来完成最适合您操作的车体设定。我们希望您能够调校出属于您的绝佳设定，所以在开始组装前，请务必先详读说明书的组装与调校教学。所有的Team Durango都是以顶级的生产标准加工制成的，所以，当您发现在组装上有任何问题的时候，请您再核对您的说明书内容，确定您是以正确的组装方式来进行组装。

若是以说明书教学以外的方式来加工或组装，您的DNX408可能会因错误的组装方式而导致不必要的损伤。若您因为某些需求而需要退还您的DNX408，则请勿有任何组装动作。所有的Team Durango的贩卖商均不对已组装使用的产品负起更换或退还责任。

Assembly Zusammenbau 組立て前に 組装

Contained in your DNX408 box are different parts bags. Each bag is marked with a letter. Within each bag are all the parts required to complete a build-stage of the kit. As noted in 'Before you begin' (above), you must ensure that you only open one bag at a time, following the correct sequence of assembly.

Before starting each build-stage, check that you have the right quantity and size of items for the build-stage. To assist you with the assembly of your DNX408, we have included full-size images of all the hardware parts laid out, so that you can place items on top of the images to check they are the correct size/length. Other items, such as those found on the mould tree, are also shown, but are not full-size.

Der Inhalt Ihres DNX408 Baukastens enthält verschiedene Teile-Beutel. Jeder Beutel ist mit einer Nummer markiert. In jedem Beutel sind genau die Teile, die sie für den Zusammenbau eines Bauabschnittes benötigen. Stellen Sie sicher, dass jeweils immer nur ein Beutel geöffnet ist, folgend der Baustufen.

Bevor Sie mit dem Zusammenbau beginnen, stellen Sie sicher, dass alle benötigten Teile im Beutel enthalten sind. Um Ihnen zu helfen, haben wir alle Teile in Originalgröße abgebildet. So können Sie Ihre Teile im Zweifel auf die Abbildung legen, um die Größe/Dimension zu prüfen. Andere Teile, wie Teile eines Plastik-Baums sind auch zu sehen, aber nicht in voller Größe.

DNX408のボックスにはそれぞれの組立てステップに応じたパーツバッグが入っております。それぞれのパーツバッグには番号がマークされています。各バッグにはそれぞれの組立ステージに応じたパーツが必要なだけパッケージされています。各組立ステージに必要なパーツバッグだけをステップに応じて開封してください。

各組立ステージを開始する前に使用するパーツが必要数入っているか確認してください。本説明書には各パーツの実物大画像を記載しています。正しいパーツ（サイズ）かどうか不安な場合にはこの画像に実際のパーツを重ね合わせる事で確認が可能ですので活用してください。

您的DNX408由不同的零件包将各项零件分开包装。每个零件包都有标示编号，每个零件包都是一个单一组成程序所转化的。如同「组装前说明」所提到，请确定您每次的组装程序都只开启需要的零件包，并遵照教学内容指示进行组装程序。

在组装之前，请先确认您的零件数量与规格都和说明书的指示一样。为了更有效地协助您完成DNX408的组装，我们会在说明书上印出与零件实际尺寸相同的示意图，以便您比对零件的规格尺寸是否正确。由于塑料零件的尺寸偏大且易于辨识，我们将只展示其相关示意图但不会以实际比例展出。

THIS KIT IS NOT A TOY.

This kit is not intended for use by anyone under the age of 14. For anyone under 14, adult supervision and assistance is recommended when building and operating the kit.

This kit is a high-performance radio controlled model racing product and could cause harm and personal injury. Team Durango Ltd accept no responsibility for any injuries caused by using or making this kit. This kit is designed for use on r/c car race tracks. It should not be used in general public areas. Team Durango Ltd accept no responsibility for any injuries caused by making or using this kit.

Please read this manual carefully to understand which ancillary items (tools, electrics, electronics etc) are used with this kit. Team Durango Ltd accept no responsibility for the operation of any such ancillary items. It is entirely the owner's responsibility to ensure this product is in good working order before operation.

Many of the items in this kit are small enough to be accidentally swallowed and are, therefore, potential choking hazards, making them potentially fatal. Please ensure that when assembling the kit, you do so out of the reach of small/young children.

All liquids etc contained in the kit are not intended for human consumption. Should you swallow any of the fluids supplied with the kit (such as shock oil, differential grease etc), please consult a physician immediately. Some of these liquids etc are flammable. Never smoke, cause sparks or excessive heat near these items. Team Durango Ltd accept no responsibility for any injuries caused by any of the parts contained within or required to make the kit.

Never touch rotating parts of the car as this may cause injury.

Do not run your car in poor light or if it goes out of sight. Any impairment to your vision may result in damage to your car or, worse, injury to others or their property.

As a radio controlled device, your car is subject to radio interference from things beyond your control. Any such interference may cause a loss of control of your car, so please consider this possibility at all times.

Sicherheitswarnungen – WICHTIG

Dieses Fahrzeug ist kein Spielzeug

Dieser Baukasten ist nicht geeignet für Jugendliche unter 14 Jahren. Bei Jugendlichen unter 14 Jahren muss eine erwachsene Person für den Zusammenbau und den Betrieb des Modells anwesend sein.

Dieses Modell ist ein Hochleistung Wettbewerbsfahrzeug und könnte erheblichen Schaden und Verletzungen hervorrufen. Team Durango Ltd übernimmt keinerlei Haftung für eventuelle Schaden, die beim Zusammenbau, oder Betrieb des Modells hervorgerufen werden.

Dieses Modell ist für den Betrieb auf Rennstrecken ausgelegt. Es sollte nicht auf öffentlichen Bereichen betrieben werden. Team Durango Ltd übernimmt keine Verantwortung für den Zusammenbau, oder Betrieb dieses Modells.

Bitte lesen Sie die Bauanleitung genau durch, um sicherzustellen, welche weiteren Werkzeuge, oder Elektronik zum Zusammenbau und Betrieb des Modells notwendig sind. Team Durango übernimmt keine Verantwortung für den Gebrauch dieser zusätzlichen Gegenstände.

Für den einwandfreien Zusammenbau und Betrieb ist Modells ist alleinig der Besitzer verantwortlich.

Einige der Bauteile sind sehr klein und könnten eingeatmet werden, was Erstickungen hervorrufen könnte. Stellen Sie sicher, dass keine Kleinkinder in die Nähe des Arbeitsbereichs kommen können.

Alle Flüssigkeiten des Baukastens sind nicht zum Verzehr geeignet. Sollten Sie eine Flüssigkeit versehentlich verschlucken, begeben Sie sich sofort zum Arzt.

Einige Teile des Baukastens sind leicht entzündlich. Rauchen Sie niemals beim Zusammenbau und Betrieb dieses Modells. Funken könnten Teile des Modells entzünden. Team Durango Ltd übernimmt keine Verantwortung für Verletzungen, die während des Zusammenbaus, oder Betrieb des Modells durch diese Dinge hervorgerufen werden können.

Berühren Sie niemals rotierende Teile des Modells. Dies könnte ernsthafte Verletzungen hervorrufen.

Betreiben Sie niemals das Modell bei schlechten Licht, oder wenn es außer Sichtweite ist. Jede Störung Ihrer Sicht, kann Ihr Modell beschädigen, oder schlimmer noch, Personen, oder Eigentum beschädigen. Als ferngesteuertes Modell kann Ihr Modell Interferenzen ausgesetzt sein, die die Kontrolle des Modells stören können. Jegliche Interferenz kann Ihr Modell außer Kontrolle bringen. Bitte beachten Sie stets diesen Umstand.

安全のために -重要！

このキットは玩具ではありません

本製品の推奨年齢は14歳以上です。13歳以下のお子様が組立・ご使用になる場合には必ず保護者の監督・補助の元で作業を進めてください。

本製品は高性能な競技用のラジオコントロールカーです。使用方法を誤りますと怪我をする恐れがあります。Team Durango Ltdは本製品を組立中、使用中に発生したいかなる怪我に対して責任を負うものではありません。

本製品はサーキット走行向けにデザインされており公共の場所（公園・駐車場等）での走行には適しません。

組立前に本マニュアルをお読み頂き、どのような工具・パーツが必要か理解して下さい。Team Durango Ltdは組立時に使用した工具等によるいかなる怪我・損害に対して責任を負うものではありません。

走行前には必ず本製品のチェックを行い、安全を確認してから走行を開始してください。R/Cカーの走行は全てお客様の責任の元に行ってください。

本製品は多数の小さなパーツを含んでおり、誤飲しますと窒息の可能性があり大変危険です。組立の際には必ず小さなお子様の手の届かない場所で作業してください。

本製品に含まれる液体・その他は飲物ではありません。万が一これら（ショックオイル、デフグリス等）を誤飲した場合にはすぐに医師の診察を受けてください。一部の液体は可燃性です。火気・炎を近づけたり投げ入れたりしないでください。Team Durango Ltdはキットに含まれるパーツや液体等で負ったいかなる怪我・損害に対して責任を負うものではありません。

回転しているパーツには怪我をする恐れがありますので絶対に触れないでください。

R/Cカーが視界の外に行った場合や薄暗い明りの元での走行は危険ですのでおやめください。視界の悪い状態で走行を続けると走行中のR/Cカーを破損したり、他人に怪我を負わせたり、器物を破損する危険がありますのですぐに走行を中止してください。

R/Cカーの走行中は外部から発せられた電波等によりR/Cカーがコントロールを失う危険性が常にあります。R/Cカーの走行中は常に電波障害発生の危険性を考慮しながら走行してください。

安全須知 - 重要！

本产品非玩具类商品

本产品不适用于十四岁以下儿童，若您的年龄或者使用者是低于十岁以下的儿童，请确认在任何组装与操作时，有成年人陪同以防任何不慎造成遗憾。

本产品为高性能的遥控竞速模型，因于产品特性，若操作或使用不当时，可能引发对人体的伤害。Team Durango对于任何不当组装或操作上造成的意外不具任何责任。

本产品为专对遥控车模型赛道开发的竞赛车种。请勿在一般的开放地使用本产品。Team Durango对于任何不当使用上造成的意外不具任何责任。

请务必详读并了解说明书中关于各种相关辅助工具的使用方式。Team Durango对于任何辅助工具之不当使用所造成的意外不具任何责任。

本产品的实际性能表现，为用户事前调校与组装之责任。

由于部份零件尺寸较小，可能引起幼同吞食、咀嚼造成意外；请用户在组装或使用本产品时，确保幼童远离以房意外发生。

产品运作中，请勿触碰任何运作零件以防意外。

本产品所含之各种流质部品，均非人体所能吸收消化。若您不慎勿食流质部品，请务必立即向医疗单位寻求协助。部份流质产品俱有易燃性，请勿在流质部品旁吸烟，或是从事任何会引发热源上升或火花的行为。Team Durango对于任何不当使用流质产品所造成的伤害俱不负任何责任。

请勿在光线不足或是超出您视距外的情况下使用本产品。由于视线不良所造成的意外，都可能不慎引起您的车体或者其他物品上的损害。

由于电波干扰问题，您的车体可能会被任何非您所控制的电波讯号干扰。这些干扰电波可能会造成您的车体失控，请您在开使操作本产品前，确实考虑此一干扰因素。

SERIOUS ABOUT RACING

The symbols below are used at various stages throughout the build of your kit. Paying close attention to these symbols, and following them properly, will ensure your kit is built properly.

Die untenstehenden Symbole werden Sie in den verschiedenen Baustufen wiederfinden. Bitte achten Sie auf diese Symbole und folgen Sie den Anweisungen, um einen korrekten Zusammenbau Ihres Modells zu gewährleisten.

下記のシンボル（記号）はキット組立の各ステージで使用されています。キットを正しく組立てる為にこれらのシンボルに注意しながら組立を進めてください。

列表中的符号将会在组装教学中出现。请您特别注意/了解这些符号的意义与出现位置。正确地遵照符号的指示，将会协助您正确地完成组装成序。

Symbol	Description (English)	Deutsch	Japanese	Chinese
	Assembly path of one item into another	Zusammenbau-Linie von einem Teil zum anderen	組付けてください	组装线/请依指示组装于另一物件上
	Press/Insert one item into another	Einsetzen, oder einpressen eines Teils in ein anderes	はめ込む/押し込む	箭头组装线/请依指示穿入零件位置
	Length after assembly	Länge nach Zusammenbau	長さ	组装零件长度
	Gap between two items	Spalt zwischen zwei Teilen	間隔	零件组装距离
	Follow arrow for direction of assembly	Folgen Sie dem Richtungspfeil beim Zusammenbau	組立ての方向に注意して下さい	请依照指式方向组装
	Follow steps in this order	Reihenfolge beachten	順序に従ってください	请依标示顺序
	This is CORRECT / This is INCORRECT	richtig / falsch	正しい / 誤り	正确程序/错误方式
	Gear grease	Getriebefett	ギアグリス	润滑油
	Differential Grease	Differentialöl	デファレンシャルグリス	差速油
	Thread Lock	Schraubensicherungsmittel	ネジロック剤	螺丝缺氧胶
	Pay special attention	Besondere Bedeutung	特に注意してください	请小心处理
	Remove with a file	Mit Feile entfernen	やすりで取り除いてください	请用剉刀修整表面
	Not Included in this kit	Nicht im Baukasten enthalten	このキットには含まれておりません	本产品不包含此项零件
	Use double-sided tape to secure	Mit doppelseitigem Kleband befestigen	両面テープで固定してください	请用双面胶固定

Required items (not included in kit)

Engine



Li-PO/LiFE Battery



Glow Plug

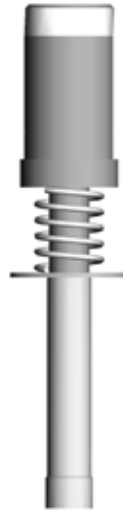

Glowplug Wrench



NiMH Battery

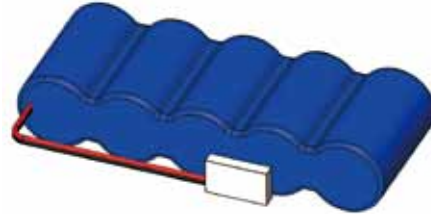

Transmitter



Receiver



Needlenose Pliers



Cross Wrench

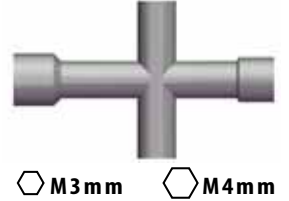

Servo



Hex Driver



Shock Oil



Grease



AA Battery



Plug



Thread Lock



Double-sided Tape



Glow Fuel



Fuel Bottle



Air Filter Oil



1

BAG

A

1:1



PIN 2.5x11.8
210018 x2



BB 8x14x4
602003 x2



S 8x10x0.1
709022 x2

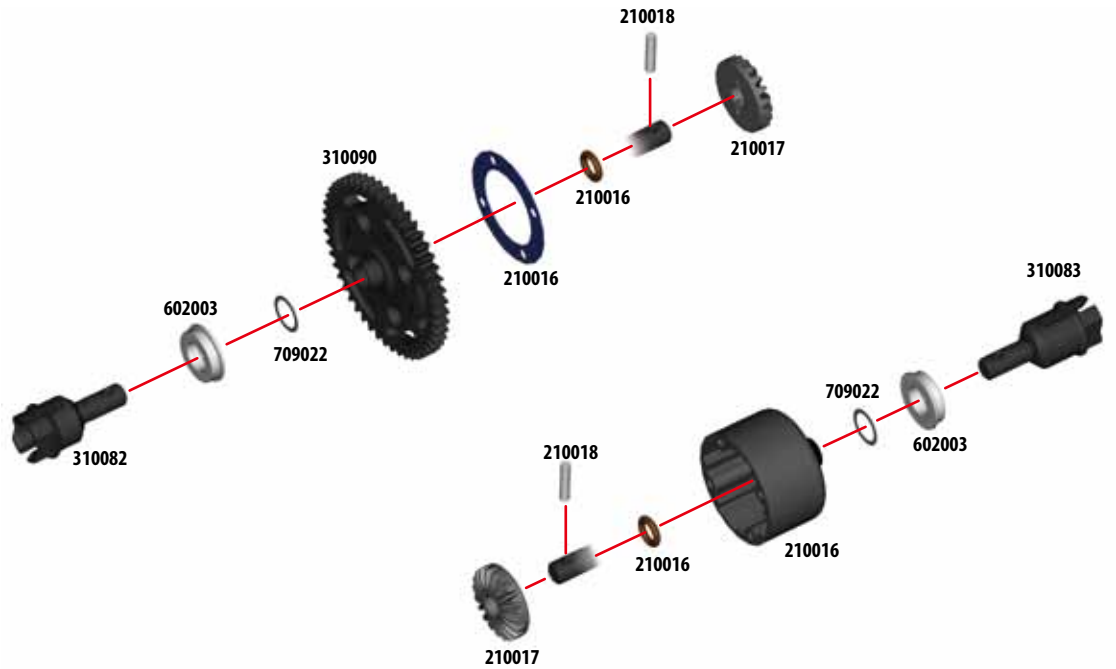

2



DIFF PINION SHAFT
210017 x2



DIFF PINION GEAR 10T
210017 x4



CS M3x12
704003 x4

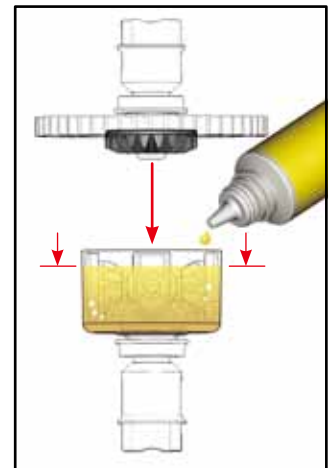
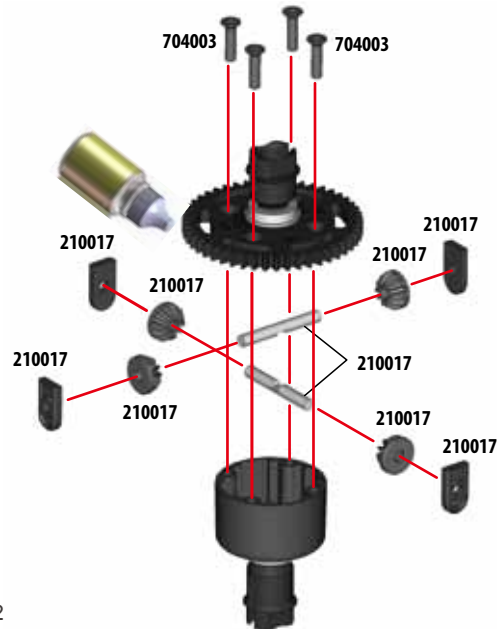

Differential Oil
70000CST # TD390032

3



PIN 2.5x11.8
210018 x4



DIFF BEVELGEAR 20T
210017 x4



BB 8x16x5
601005 x4

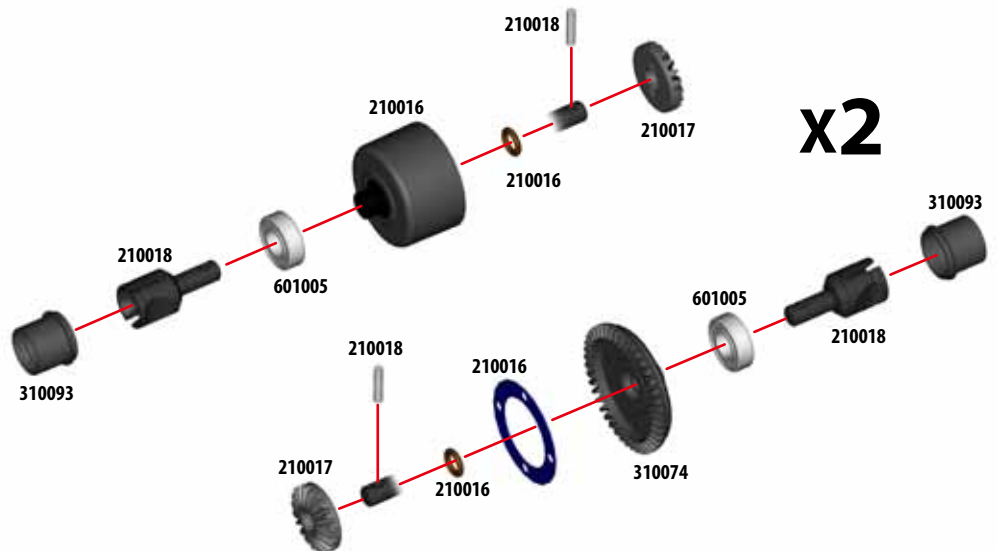

4



DIFF PINION SHAFT
210017 x4



DIFF PINION GEAR 10T
210017 x8



CM M3x12
704003 x8



Differential Oil
Front 70000CST # TD390032
Rear 20000CST # TD390004

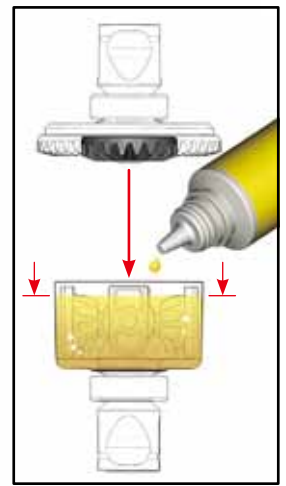
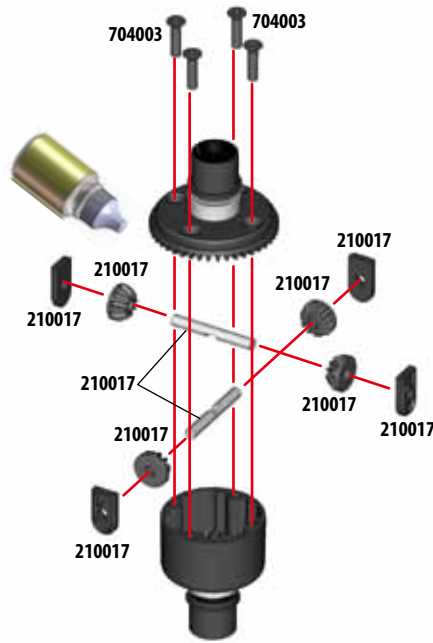

x2

5



MID DRIVESHAFT BUSHING
210022 x2



PIN 2.5x13
210022 x2



SETSCREW M3x4
701002 x2



BB 10x15x4
601003 x4



A-Snapping
310092 x2



Thread Lock



Gear Grease

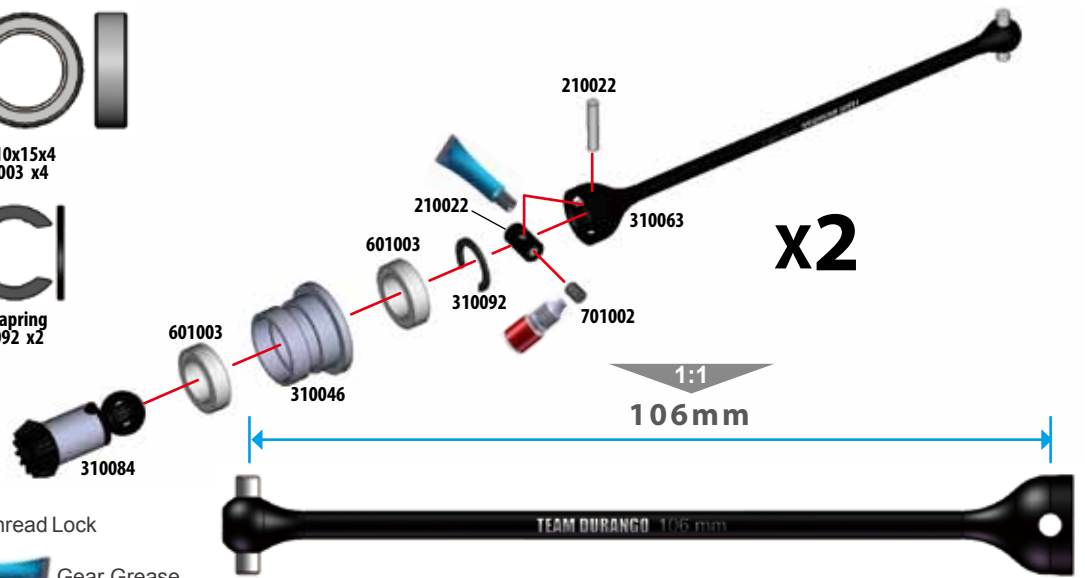

x2

1:1
106 mm

6



SH M3x12
704022 x6



Gear Grease

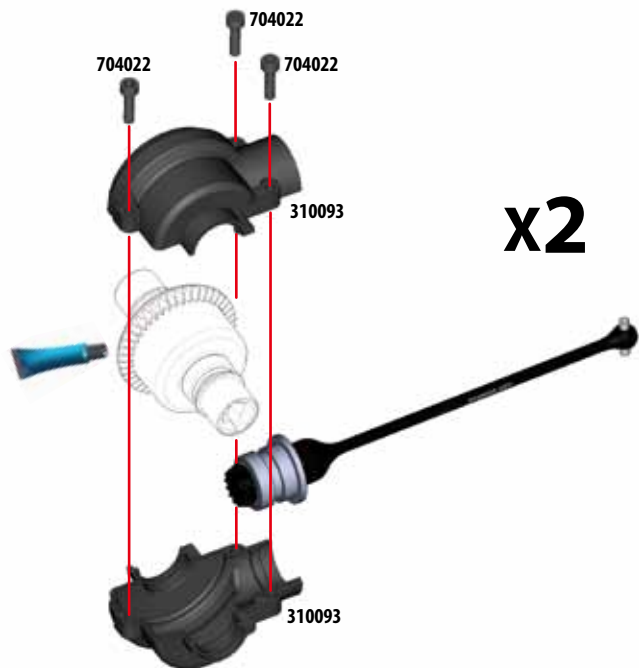

x2

7

BAG
C
1:1

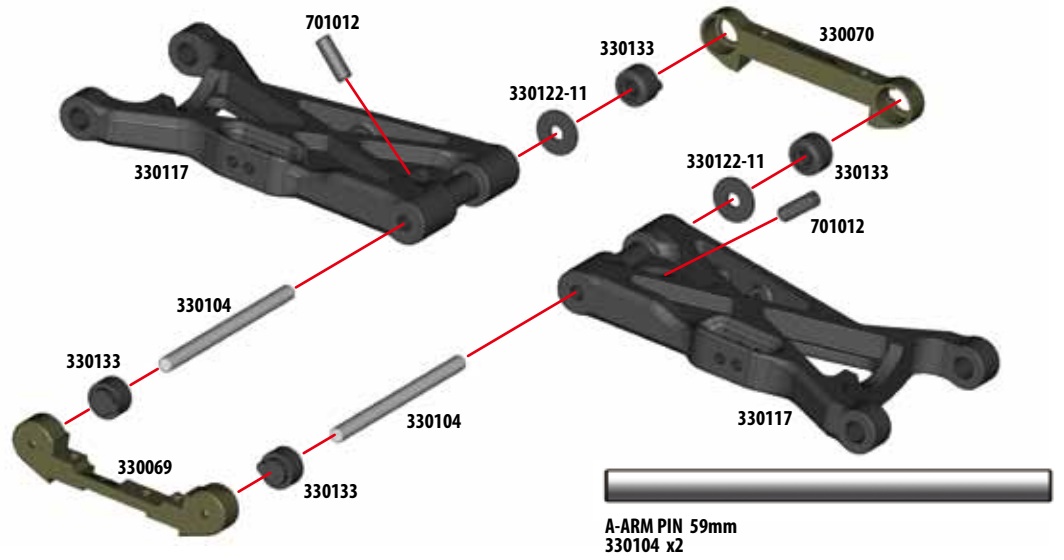

8

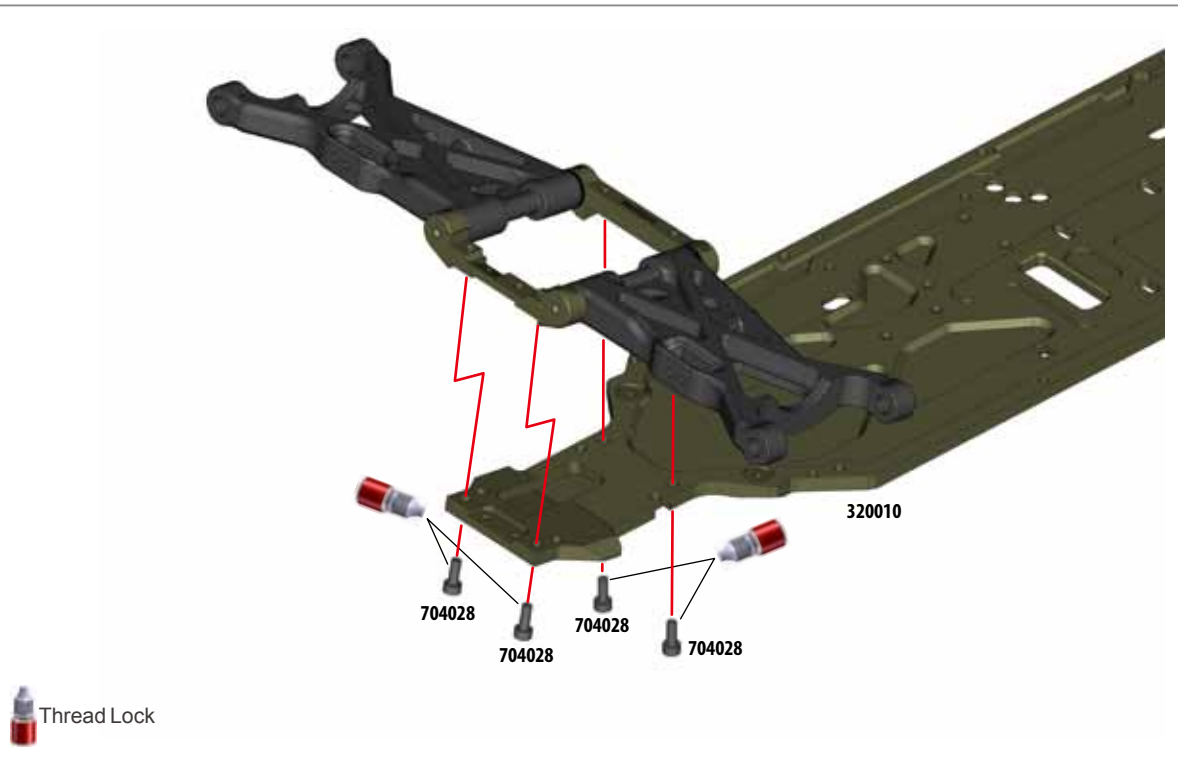

9

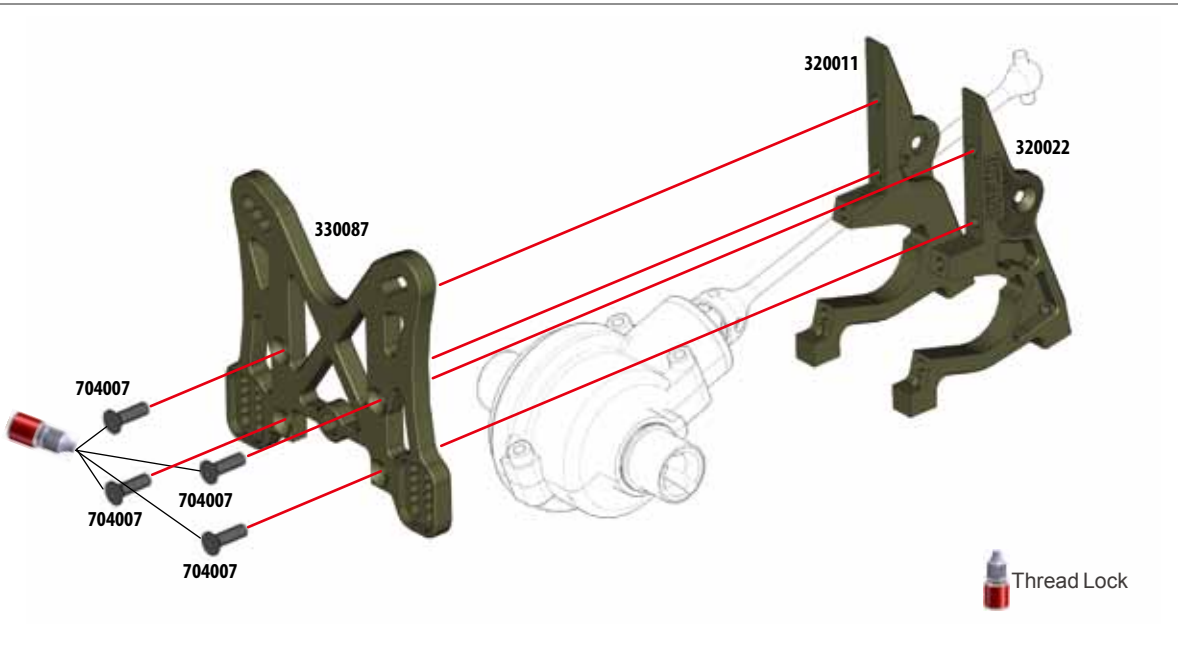

10



SH M3x8
704028 x4



Thread Lock

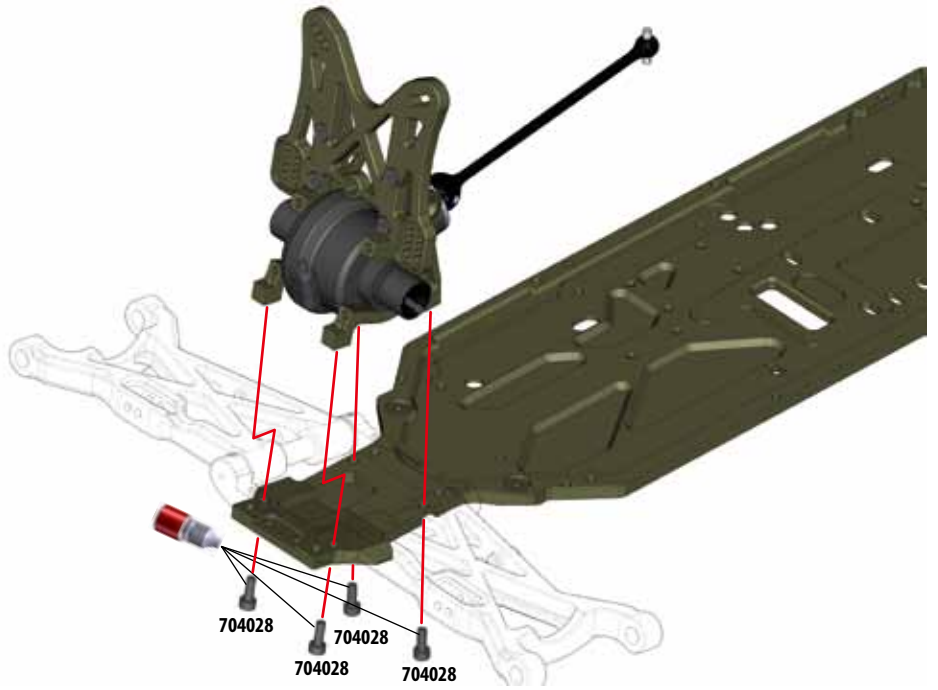

11



CS M3x8
704006 x2



SH M3x16
704024 x4



Thread Lock

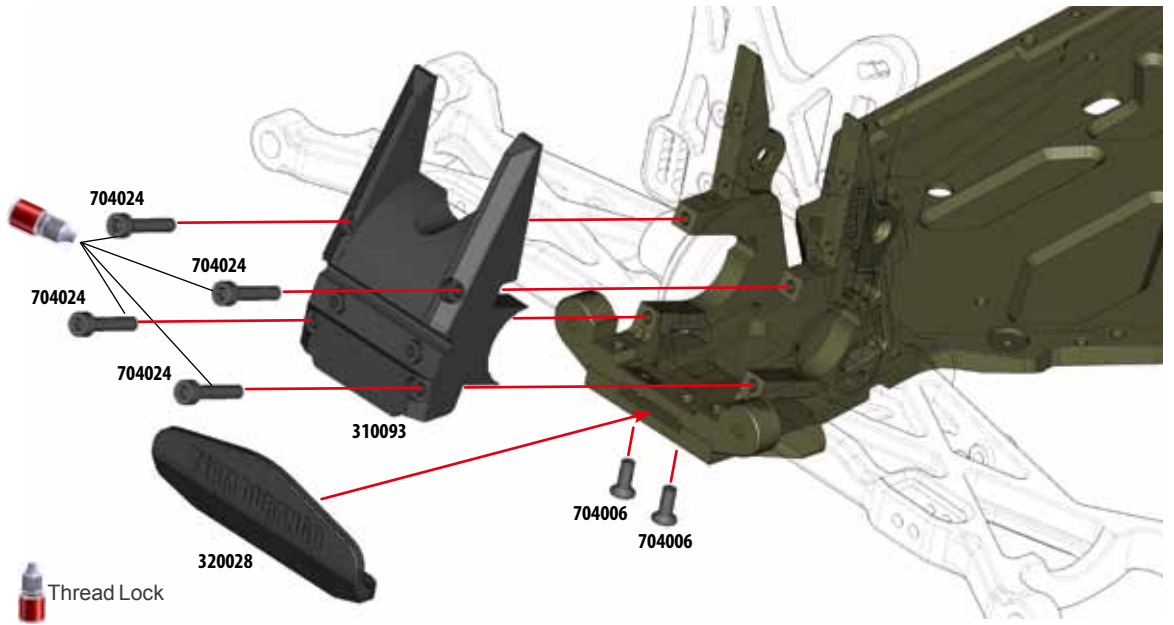

12

BAG

D

1:1



330122-9 (2.0mm) x2



330122-10 x2



SETSCREW M3x12
701012 x2

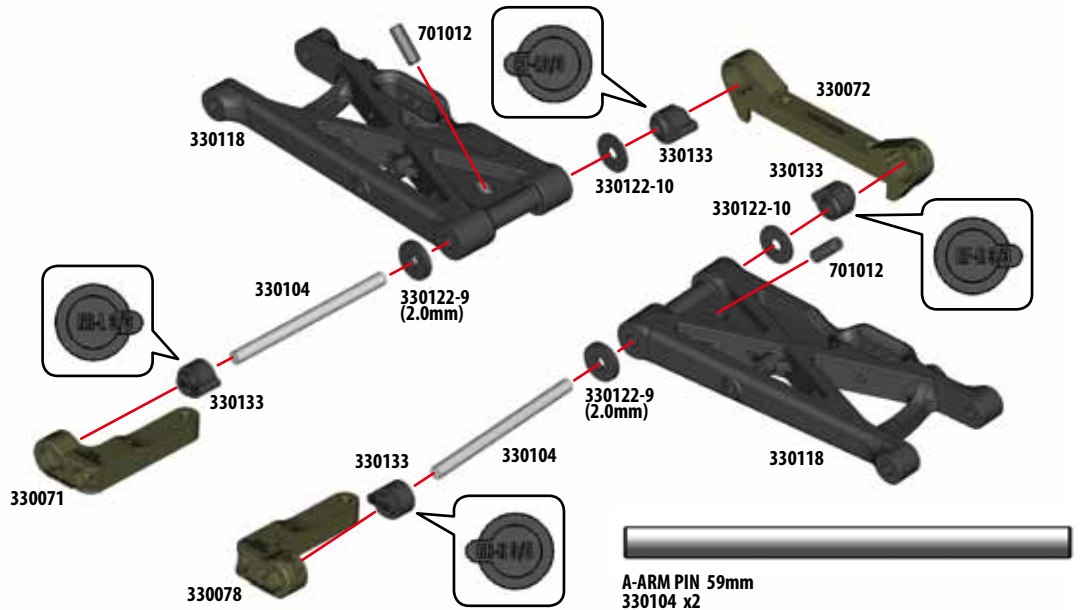

13



SH M3x10
704009 x4



SH M3x8
704028 x2

Tuning tip

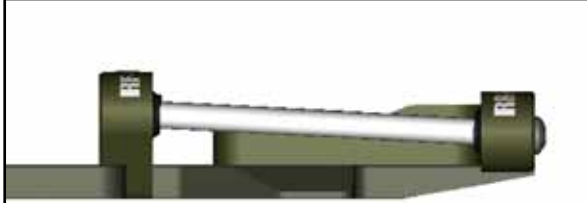

3/3 Inserts give 3° toe-in and 3° kick up

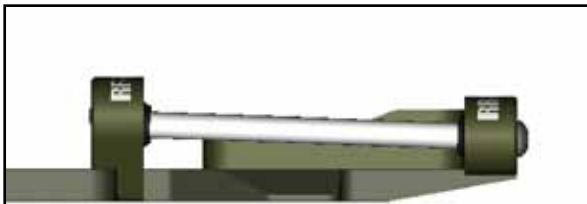

3/2 Inserts give 3° toe-in and 2° kick up

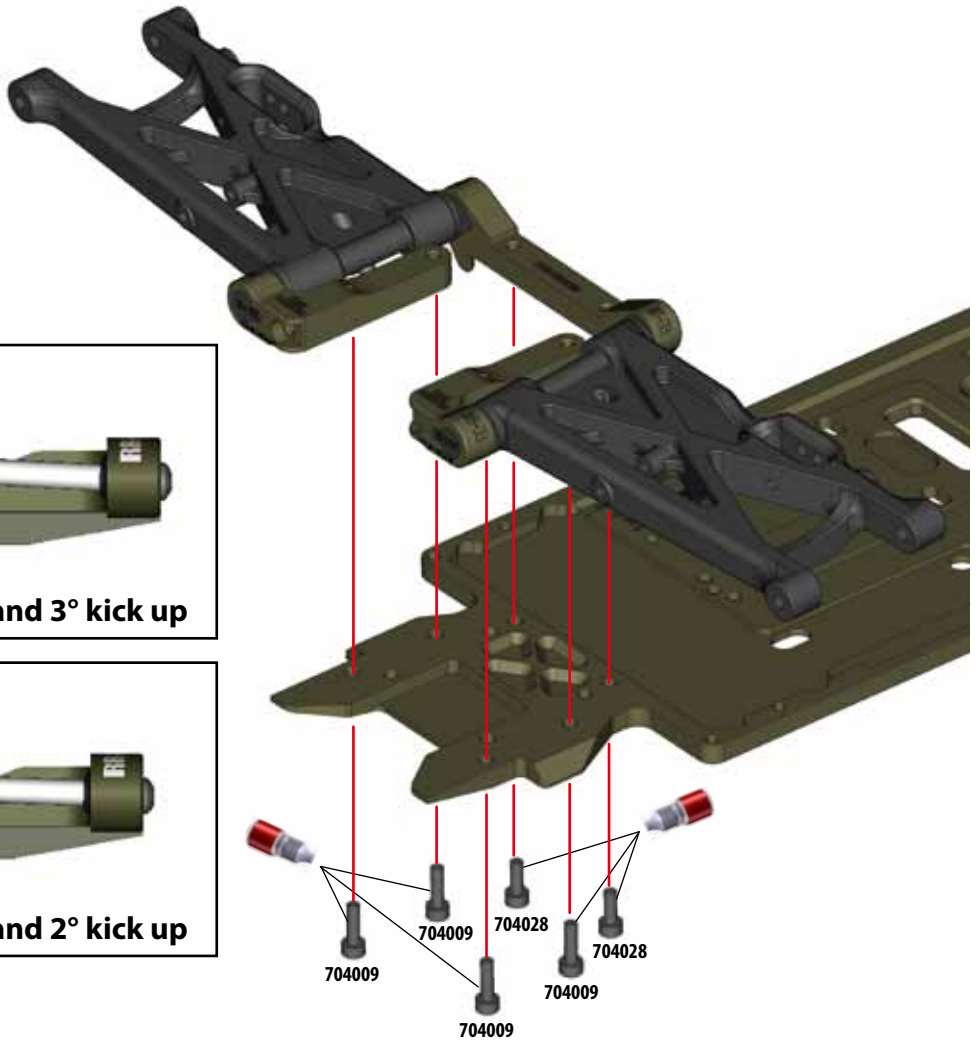

Thread Lock

14



SH M3x10
704009 x2



SH M3x16
704024 x2

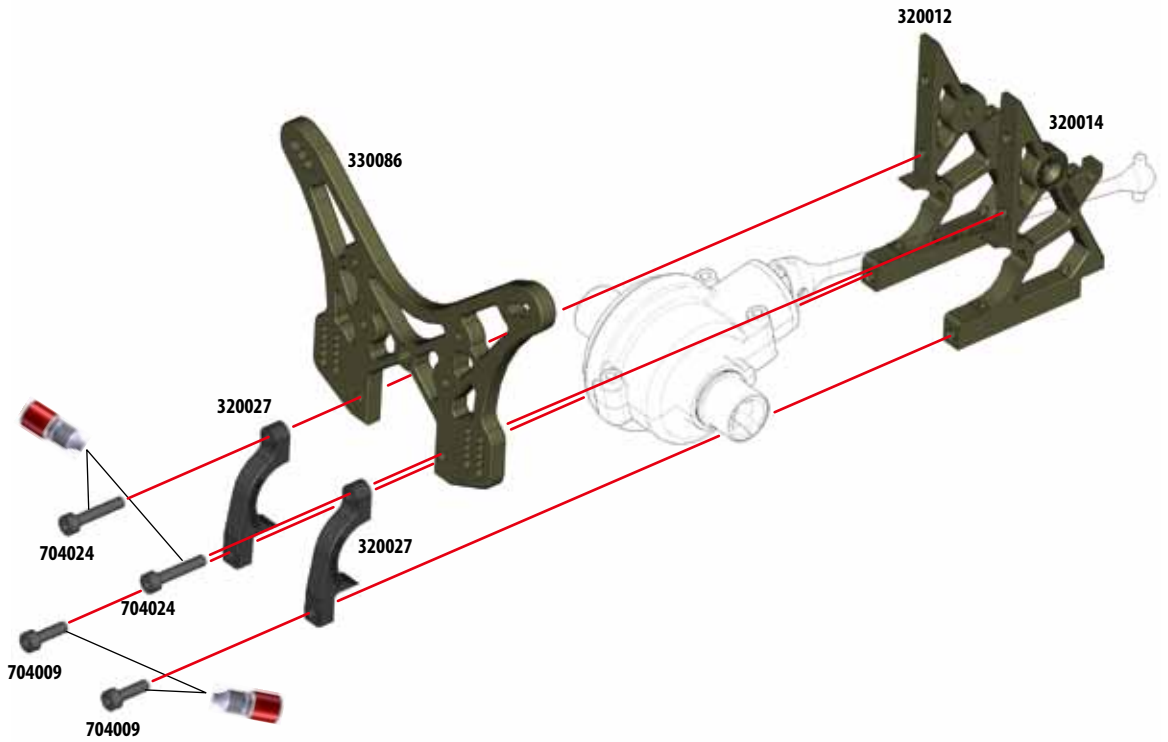

Thread Lock

15



BH M3x8
705002 x2



SH M3x10
704009 x4

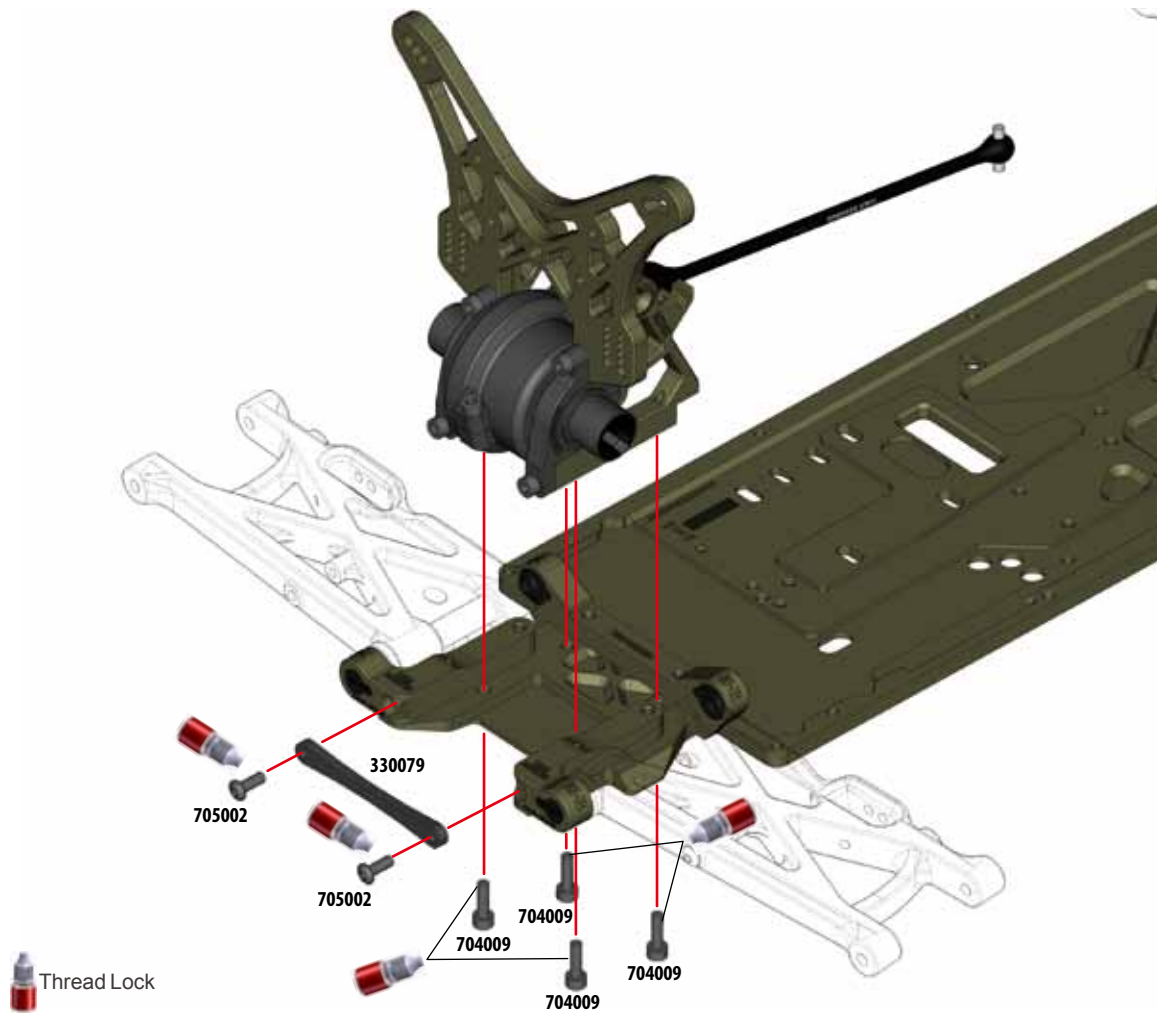

16



1:1



CVD BOOT
310059 x2

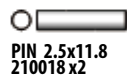

PIN 2.5x11.8
210018 x2

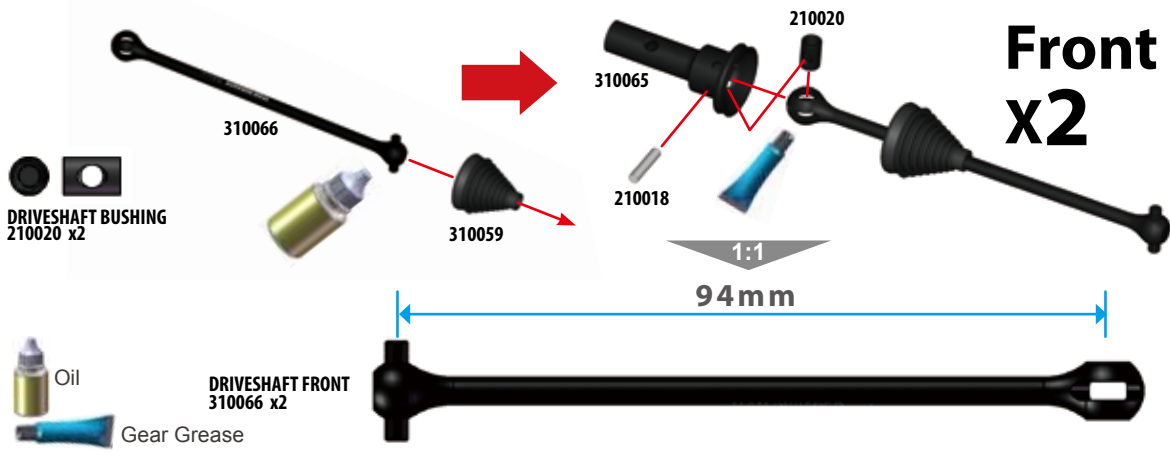

17



CVD BOOT
310059 x2

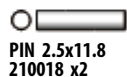

PIN 2.5x11.8
210018 x2



DRIVESHAFT BUSHING
210020 x2

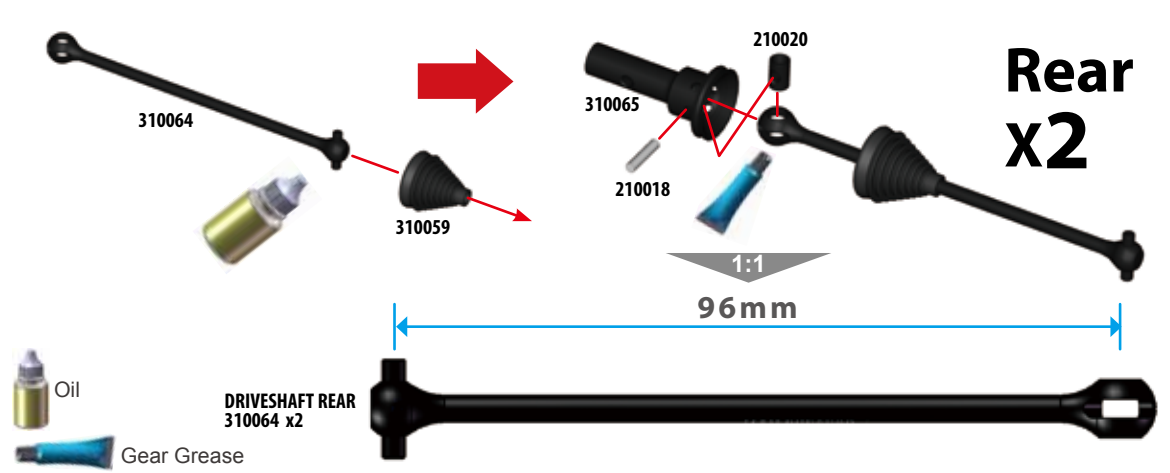

18



PIN 4x18
330106 x4



PIN 3x16.9
310087 x2



SETSCREW M3x5
701003 x4



701009 x2



S 8x10x0.1
709022 x2

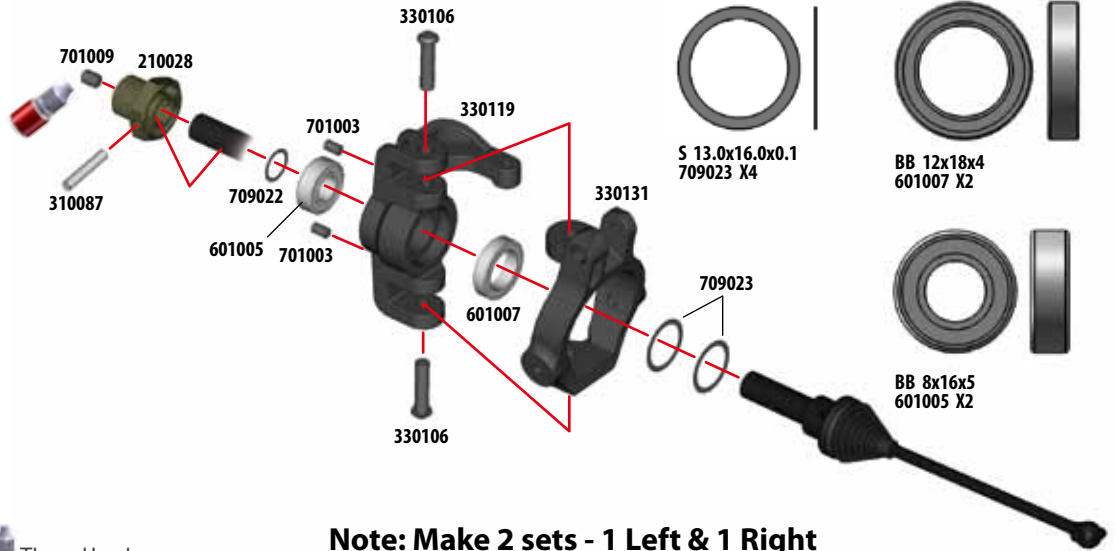

Note: Make 2 sets - 1 Left & 1 Right

19



PIN 3x16.9
310087 x2



701009 x2



S 8x10x0.1
709022 x2



S 13x16x0.1
709023 x4

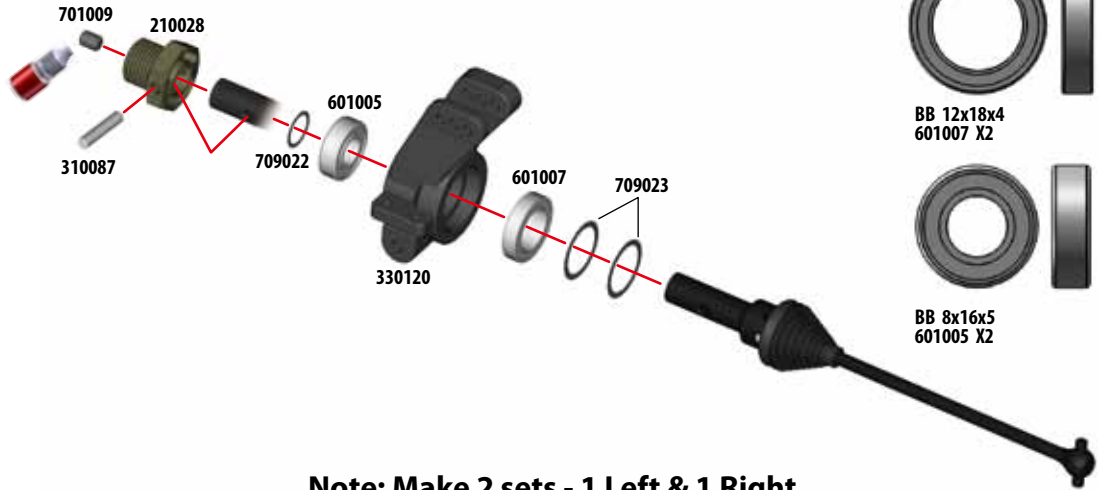

Note: Make 2 sets - 1 Left & 1 Right

20

BAG

F

1:1



A-ARM BUSHING
330076 x4



BH M4x18
705022 x4

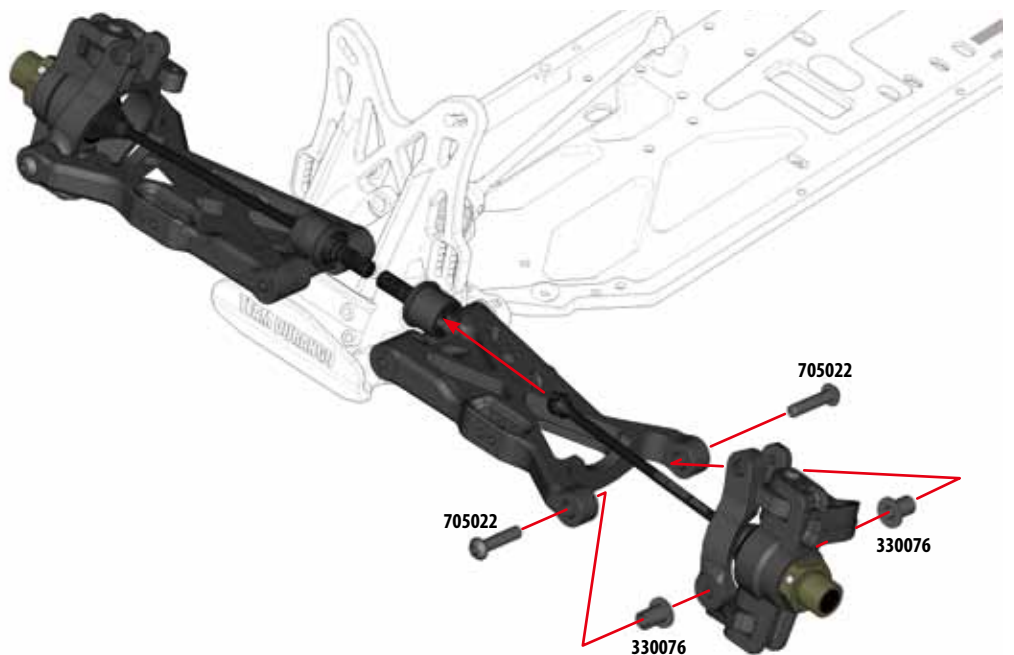

21



A-ARM PIN REAR SHORT
330105 x2



NUT M3 high
715002 x2

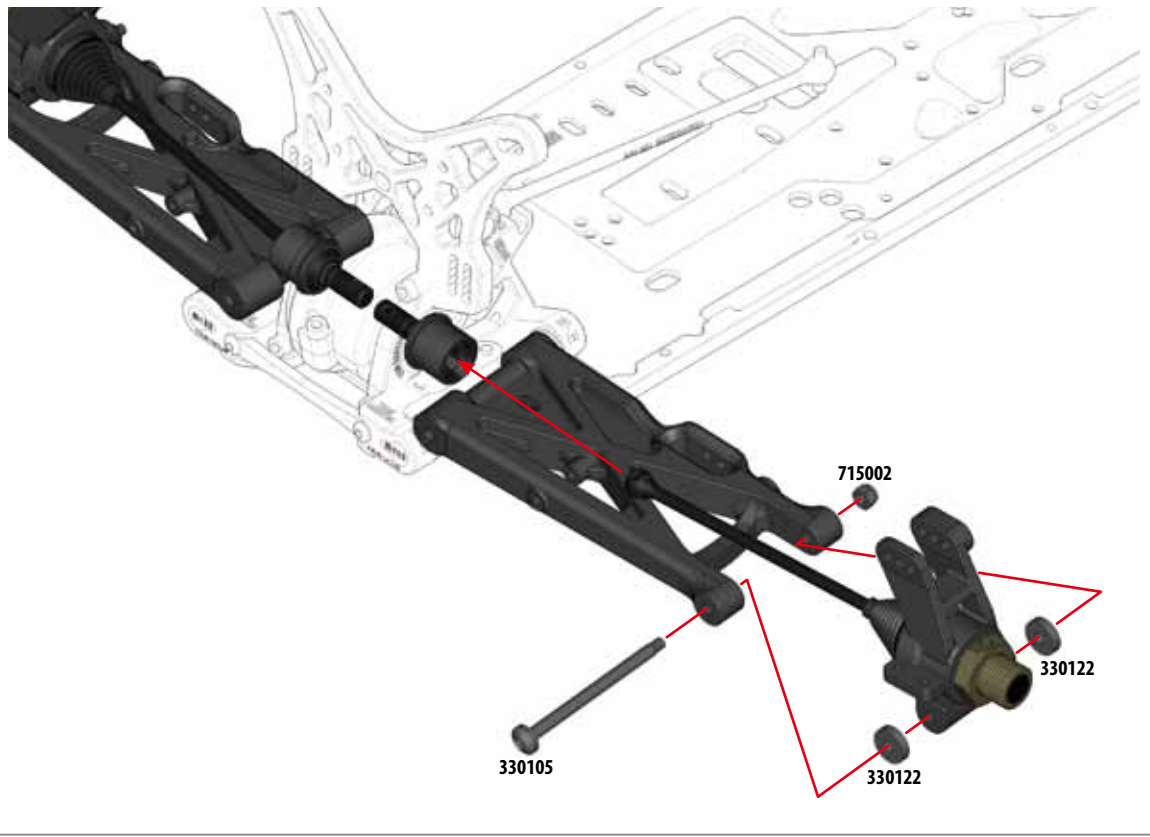

22



ANTI ROLLBAR PIVOT BALL
330075 x4



SETScrew M3x10
701005 x4

330075

x4

330121
(Short)

701005

330074

330121
(Long)

1:1



23



SETScrew M3x4
701002 x2



SETScrew M3x3
701004 x2



BH M3x8
705002 x2



BH M3x18
705012 x2

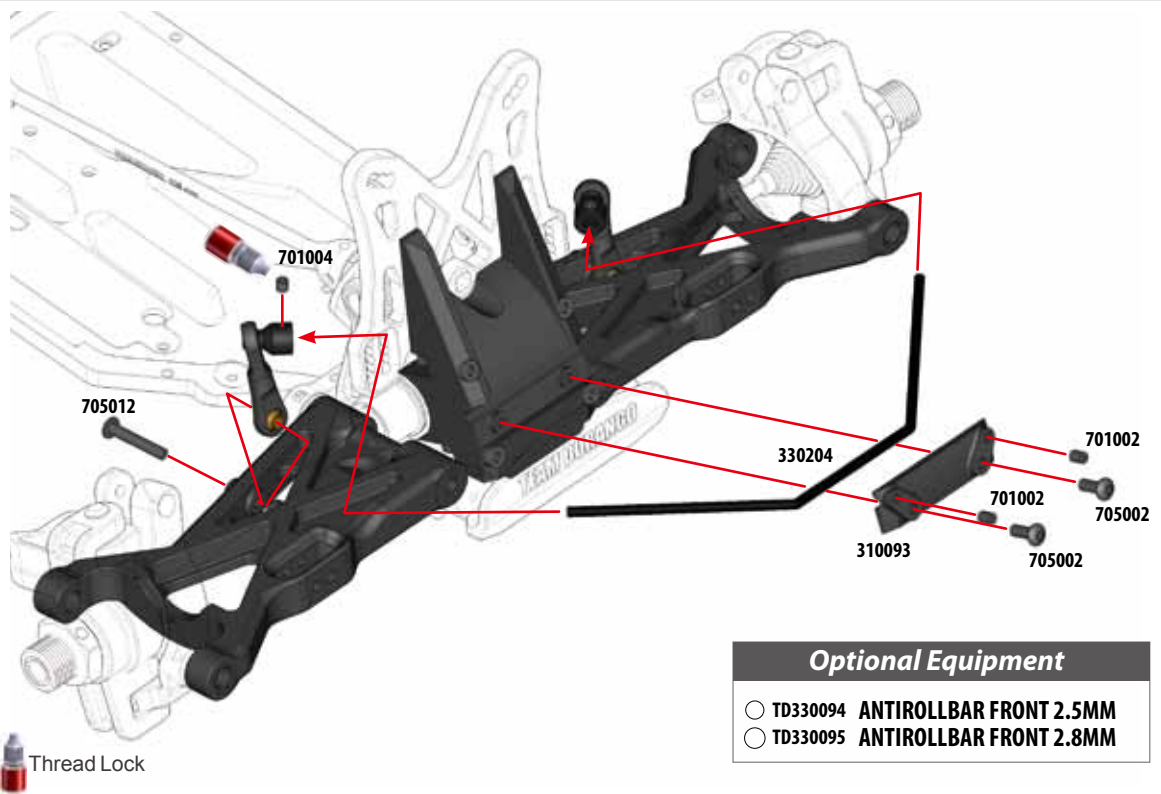

Optional Equipment

- TD330094 ANTIROLLBAR FRONT 2.5MM
- TD330095 ANTIROLLBAR FRONT 2.8MM

SETSCREW M3x4
701002 X2

SETSCREW M3x3
701004 X2

BH M3x8
705002 X2

BH M3x18
705012 X2

Optional Equipment

- TD330092 ANTIROLLBAR REAR 3,3MM
- TD330093 ANTIROLLBAR REAR 2,5MM

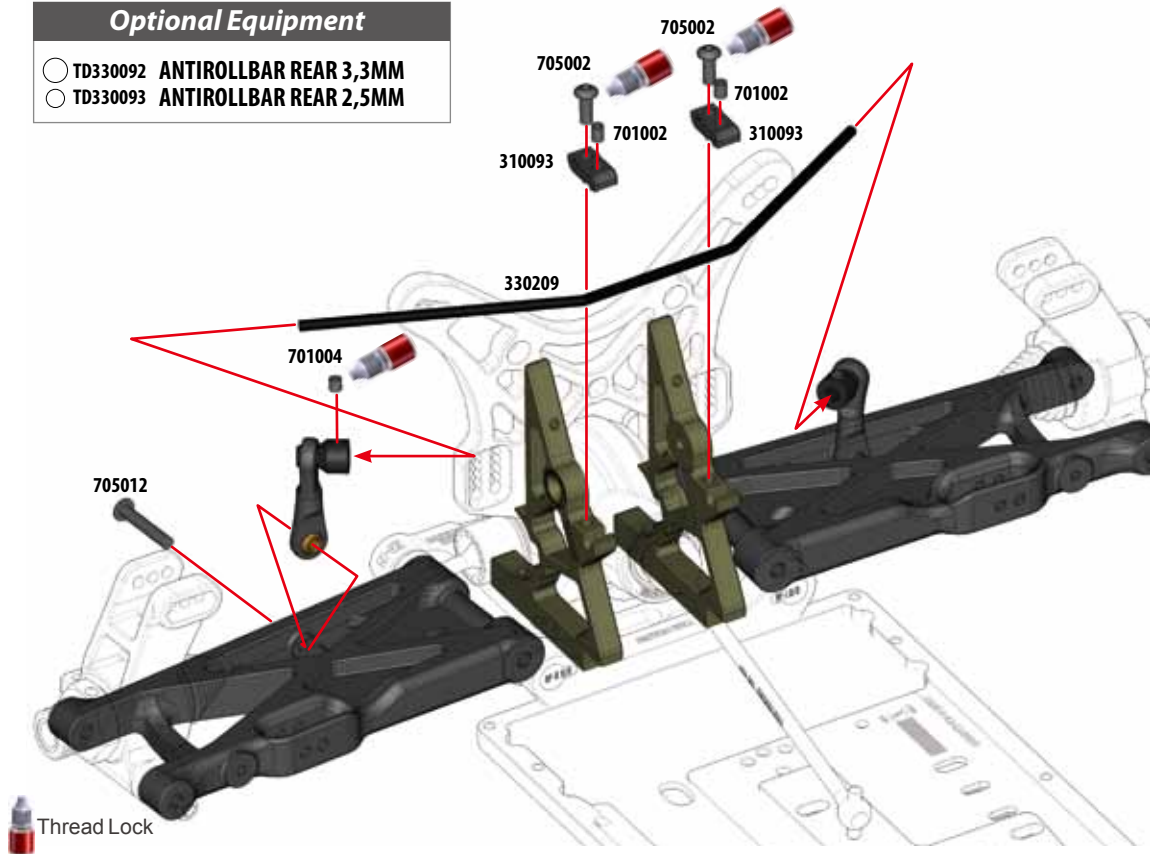

BAG

G

1:1

STEERING PLATE SCREW M3x10.5
270004 x2

SPACER 6x10x2
340012 x2

SAVER SPRING
340015 x1

BB 6x10x3
601004 x4

NUT M3 high
715002 x2

STEERING PLATE BUSHING
270004 x2

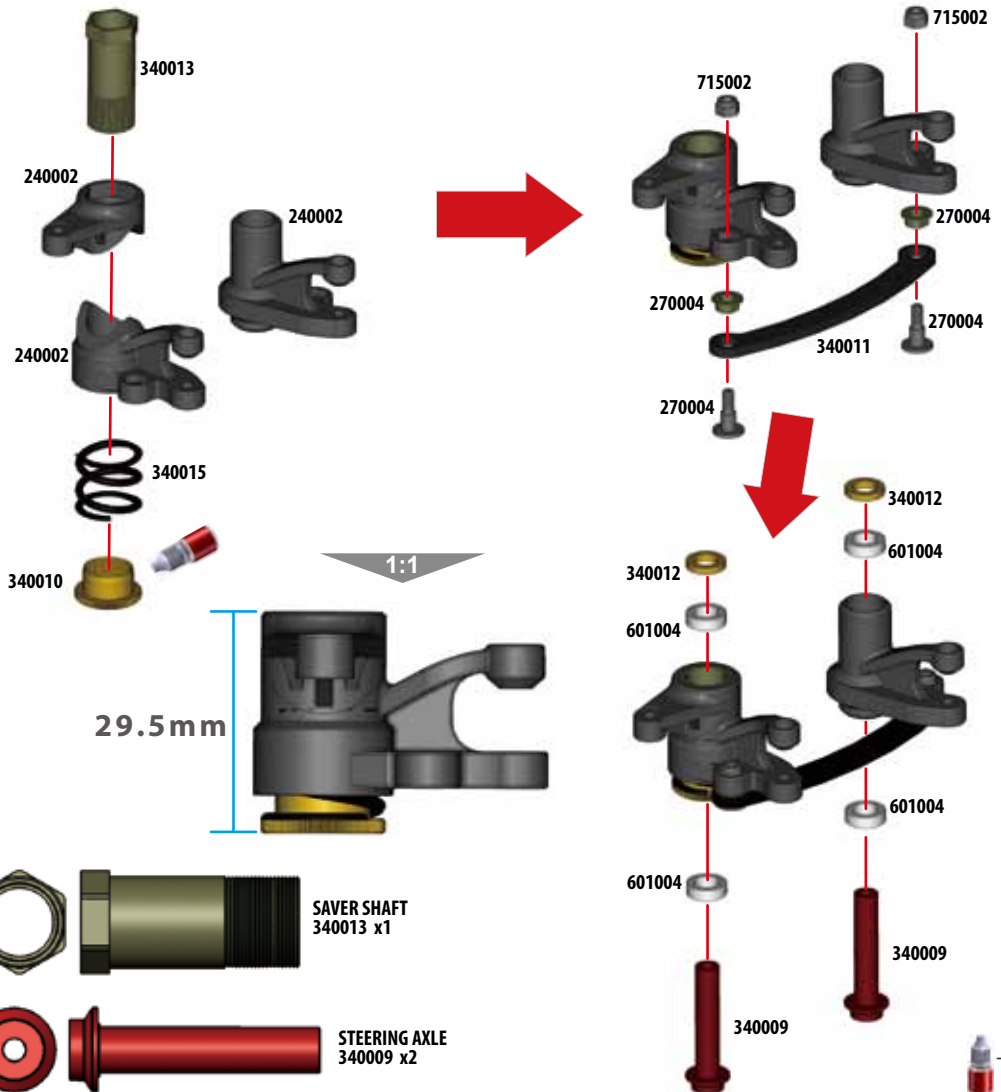

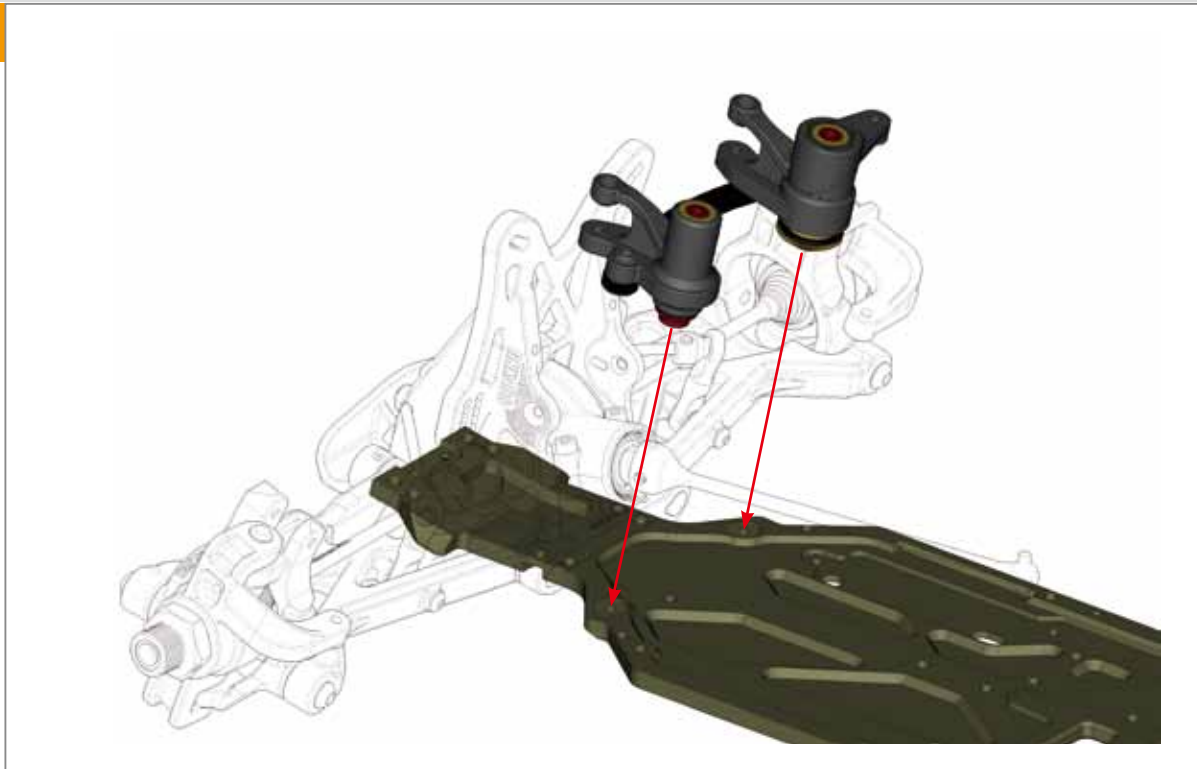

CS M3x8
704006 x2



CS M3x10
704007 x2



SH M3x40
704025 x2



NUT M3 high
715002 x2

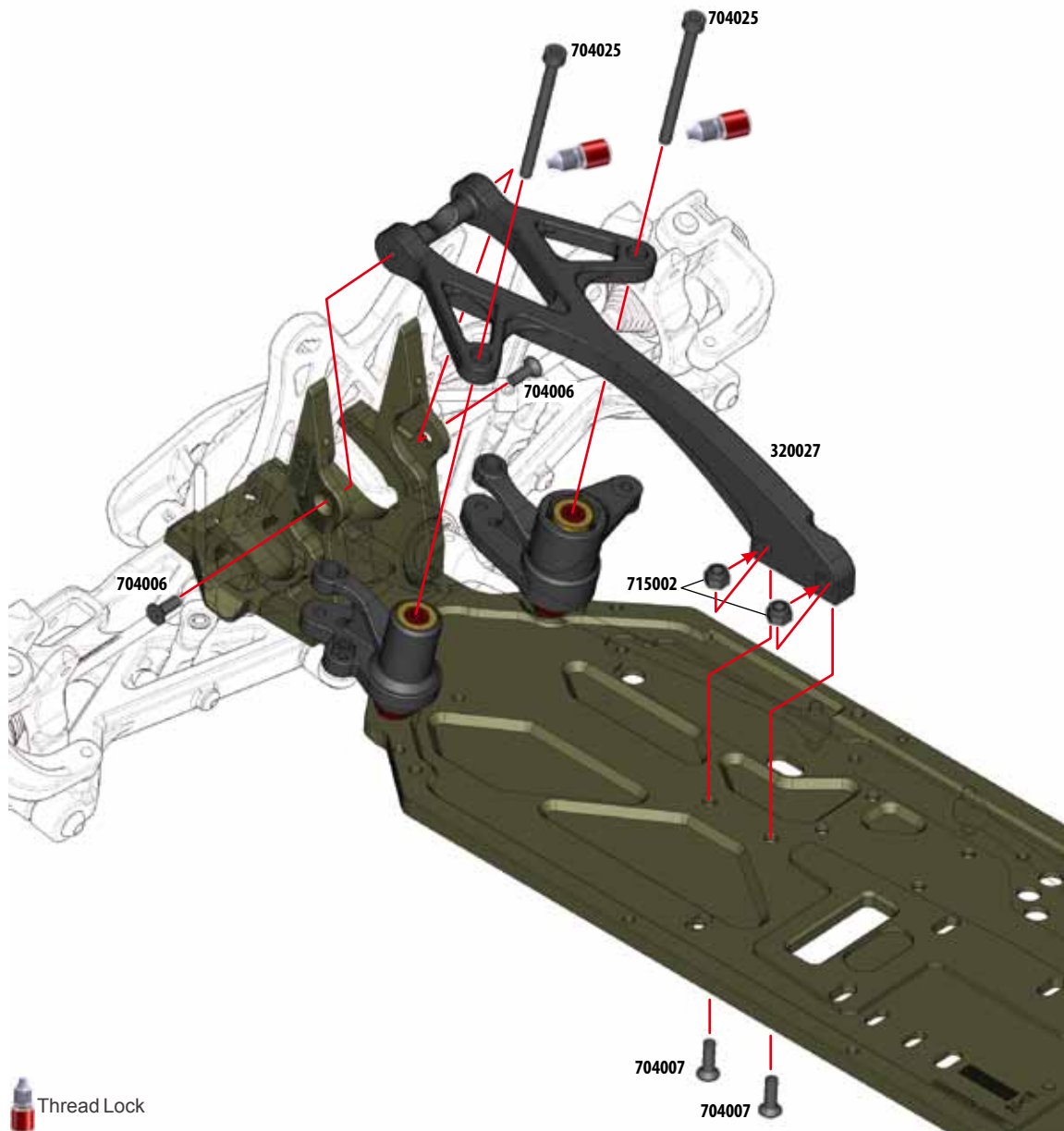

28



REARSTIFFENER SHAFT
220004 x1



REARSTIFFENER BUSHING
220004 x2



RUBBER BUSHING
220004 x2



CS M3x12
704003 x2



CS M3x14
704013 x3



NUT M3 high
715002 x2

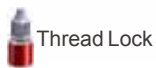
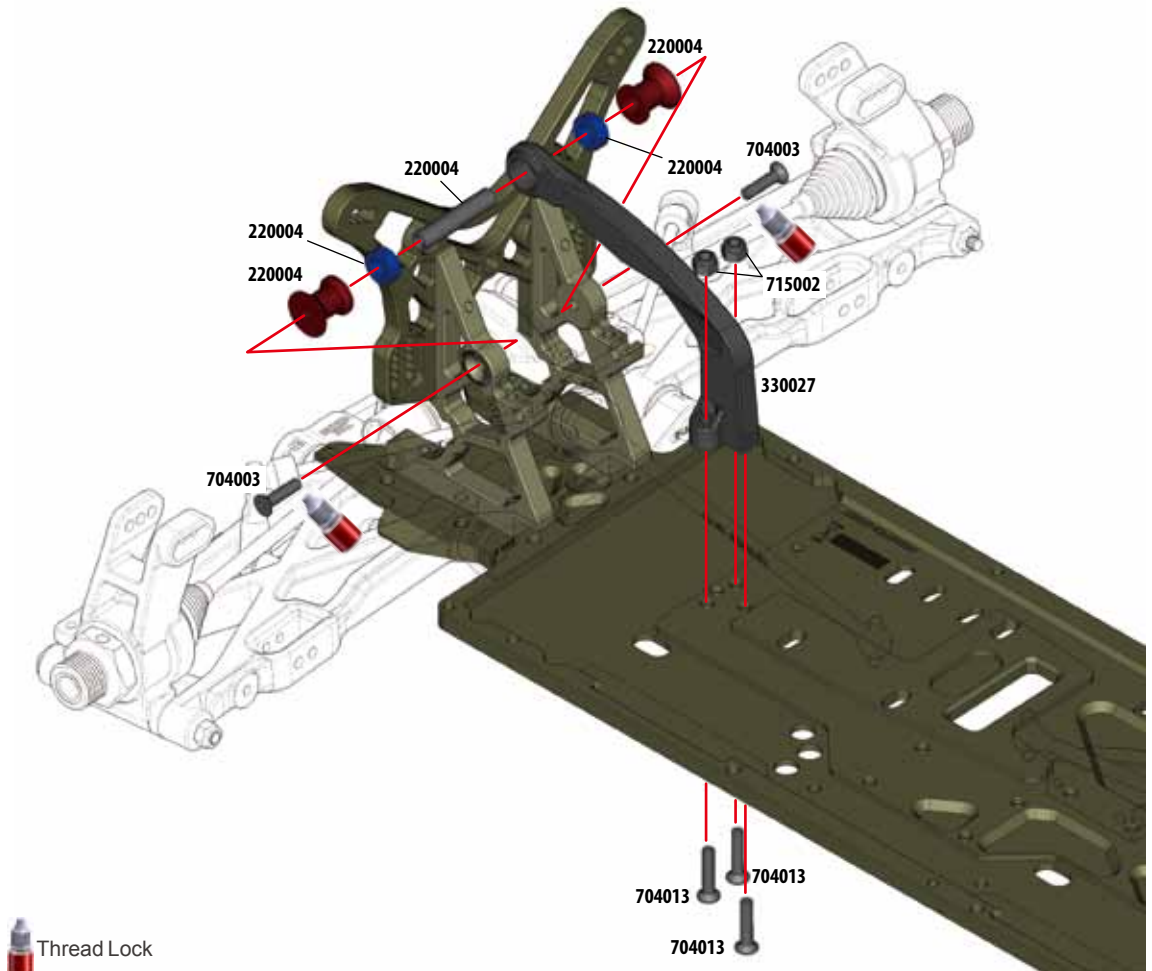

29



PIVOTBALL A-TYPE
330073 x4

Front Camber Link

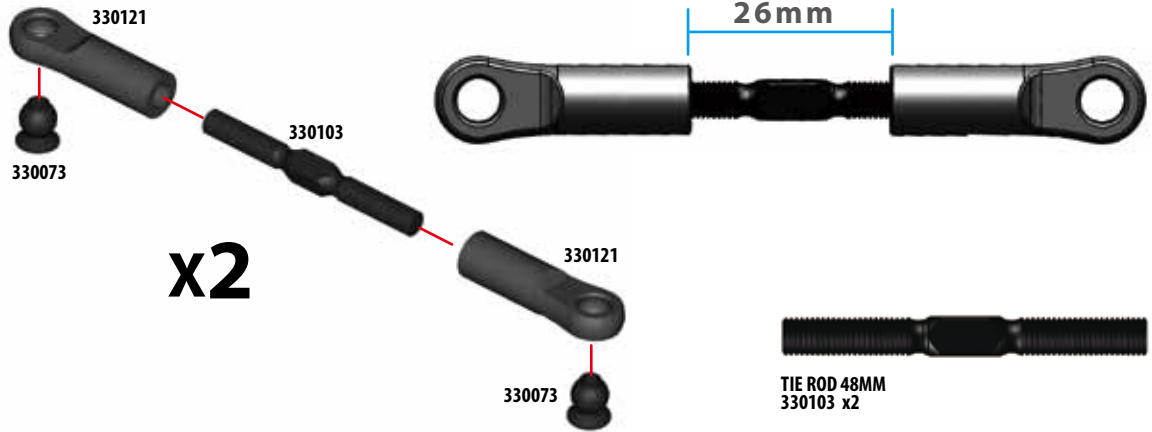

30



PIVOTBALL A-TYPE
330073 x4

Steering Link

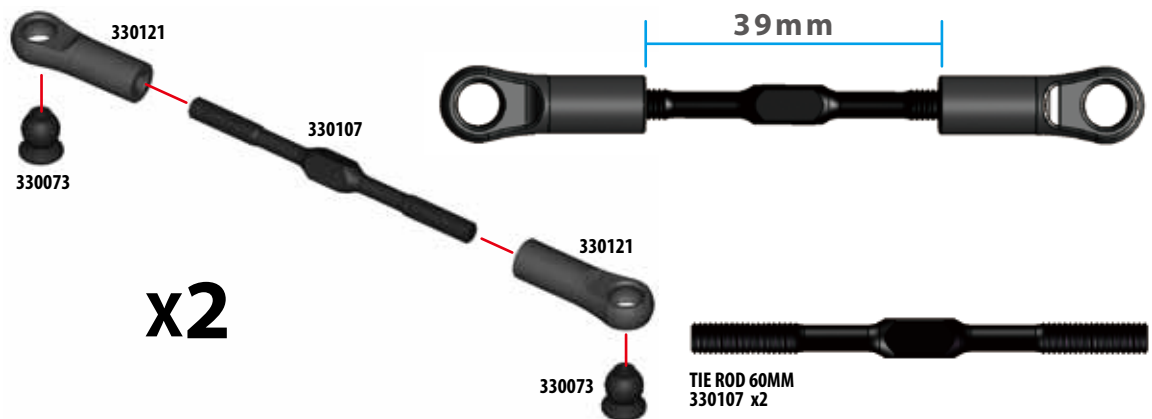



PIVOTBALL A-TYPE
330073 x4

Rear Camber Link

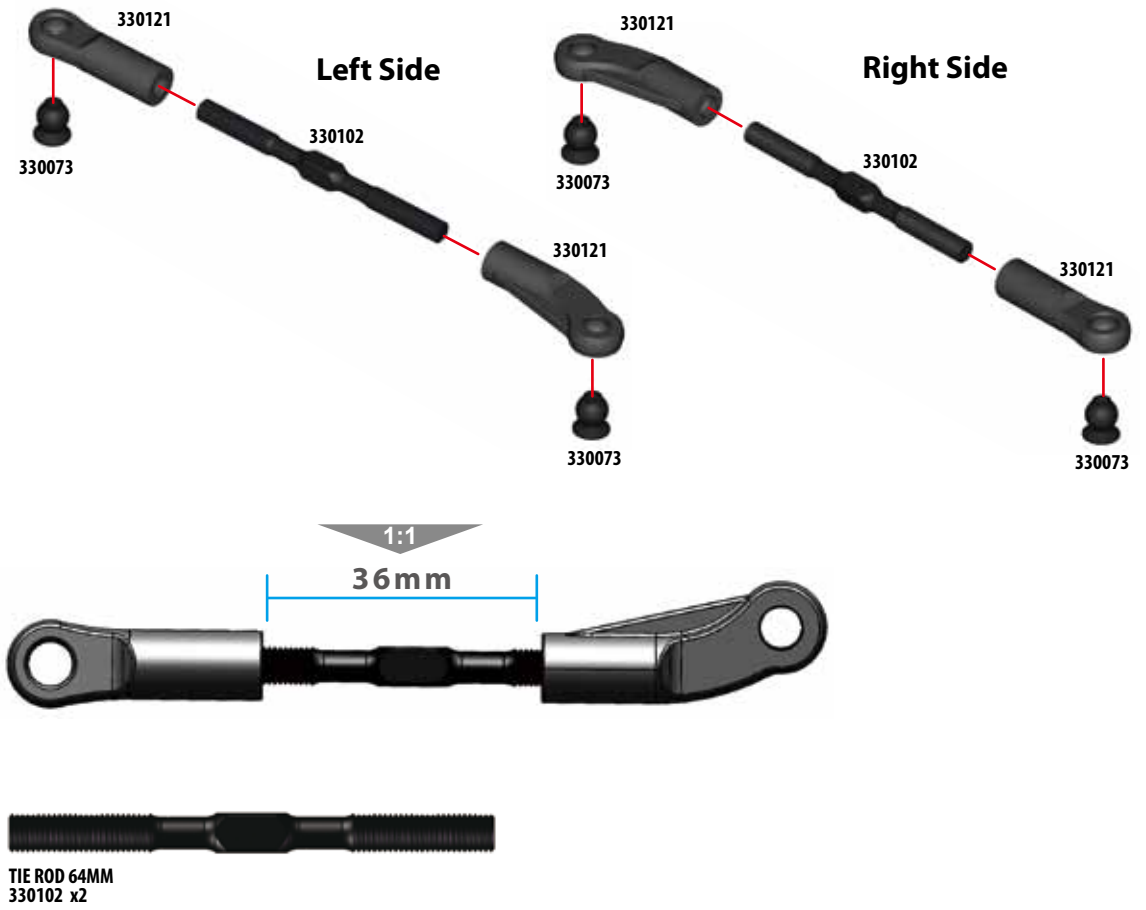

BH M3x18
705012 x2



BH M3x22
705013 x2



SHIM A-TYPE
709011 x2



NUT M3 high
715002 x4

Front Camber Link Installation

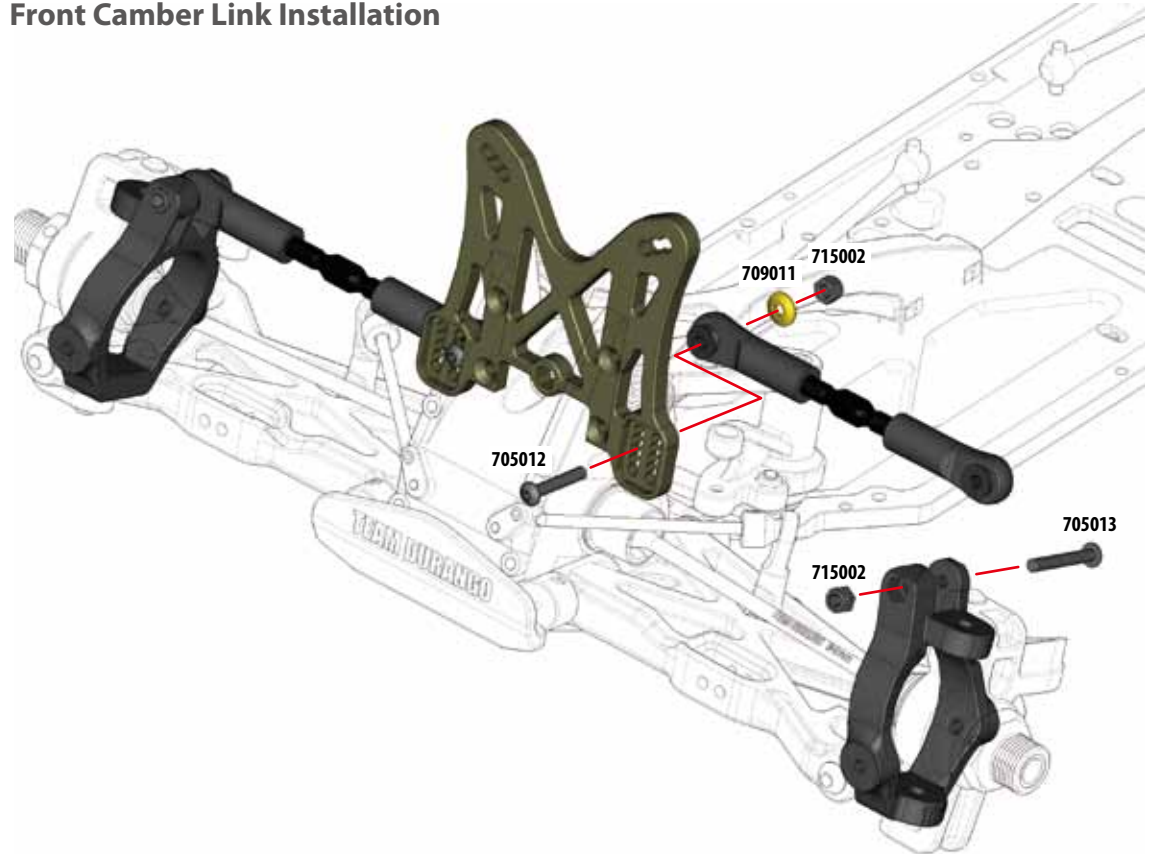

33

Steering Link Installation



SH M3x16
704024 x2



BH M3x18
705012 x2



SHIM A-TYPE
709011 x2



NUT M3 high
715002 x4

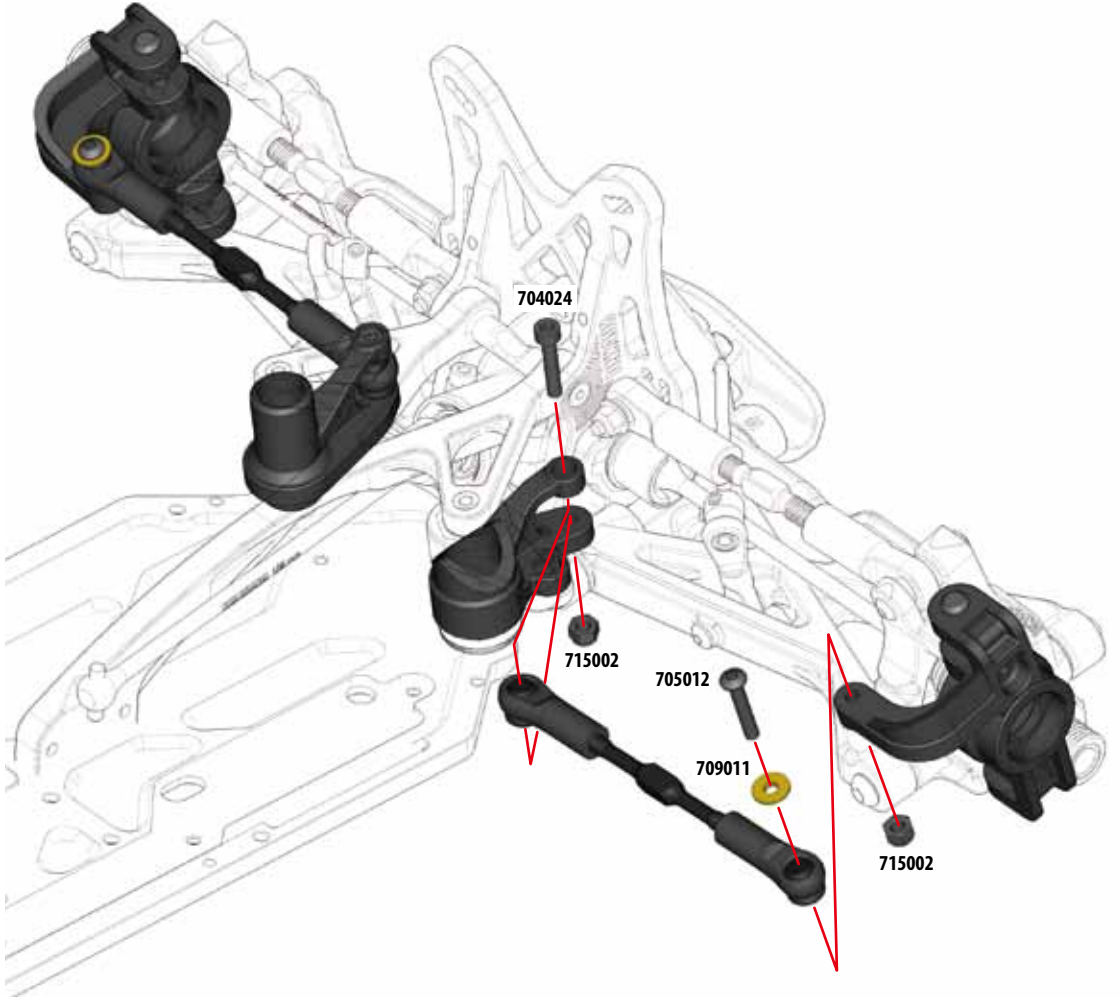

34

Rear Camber Link Installation



BH M3x18
705012 x2



BH M3x20
705014 x2



SHIM A-TYPE
709011 x4



NUT M3 high
715002 x4

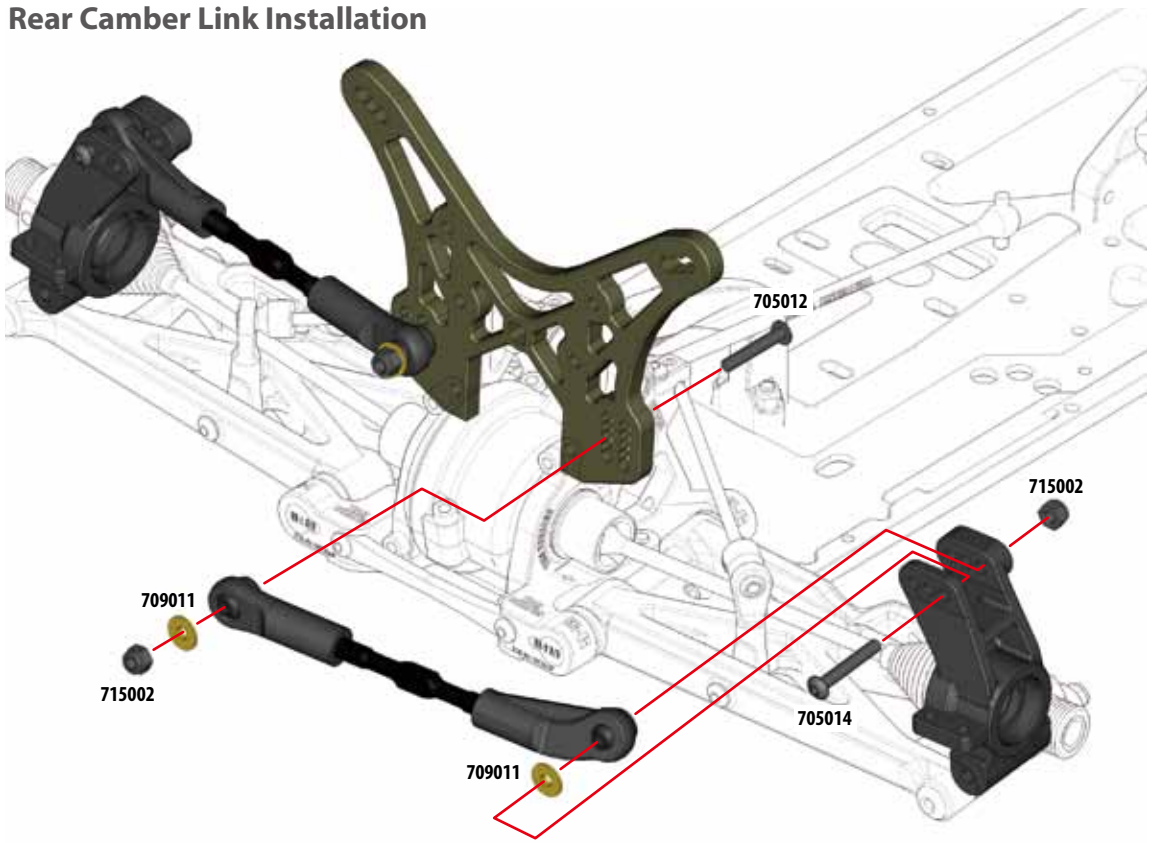

35



BH M3x14
705011 x2

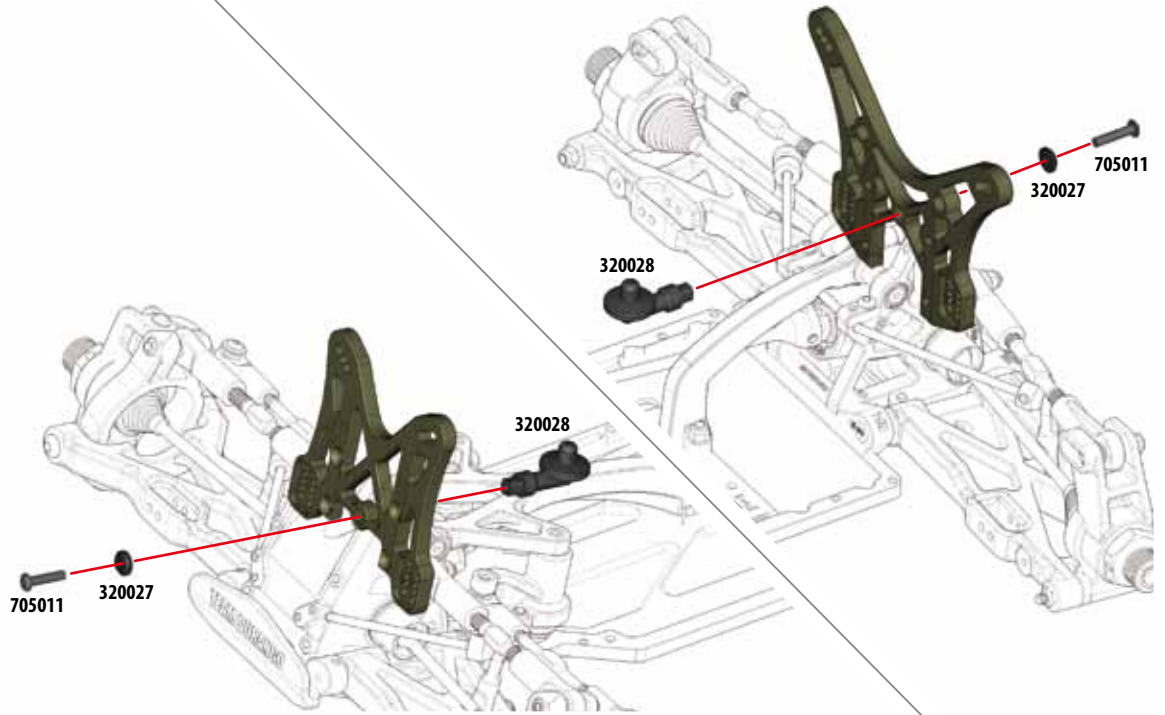

36



BH M3x18
705012 x4



NUT M3 high
715002 x2

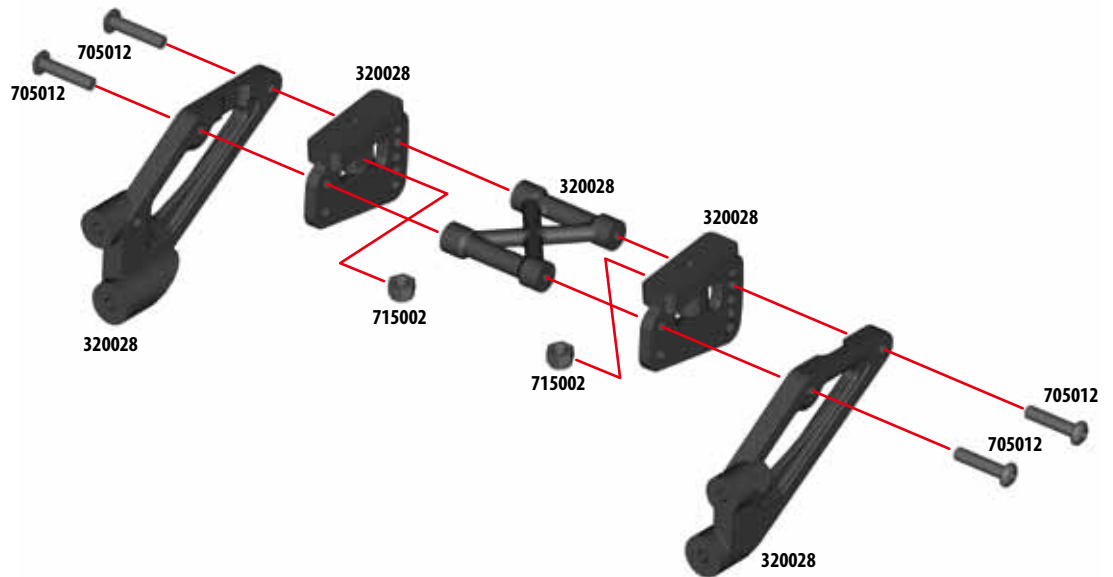

37



SH M3x12
704022 x2



SH M3x16
704024 x2



NUT M3 high
715002 x2

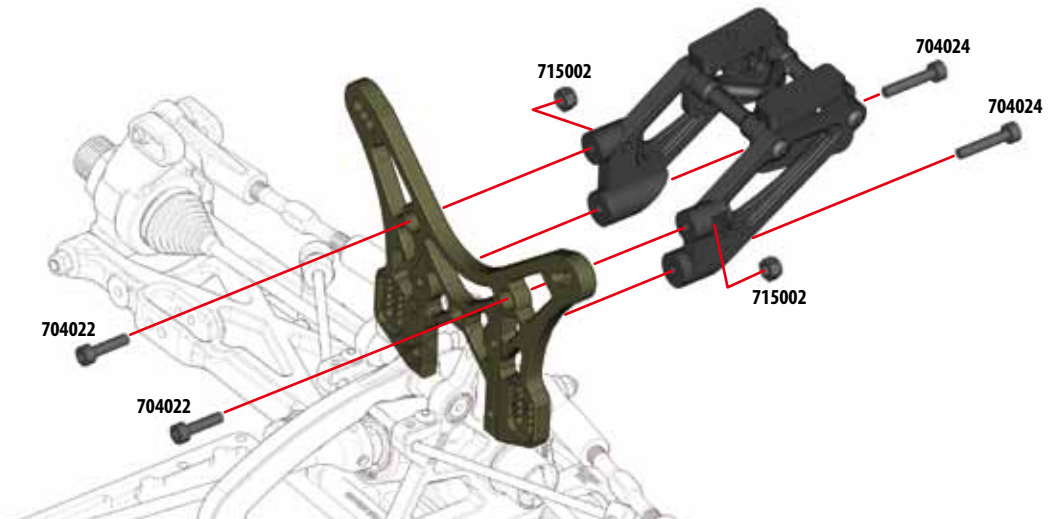

38

BAG

1:1



BRAKEPAD SPRING
210029 x4



BRAKE SCREW M3x20
210029 x4



SETSCREW M3x5mm
701003 x2



CS M3x10
704007 x2

BRAKE BOLT SHORT 6x8
390011 x1

BRAKE BOLT LONG 6x13
390012 x1

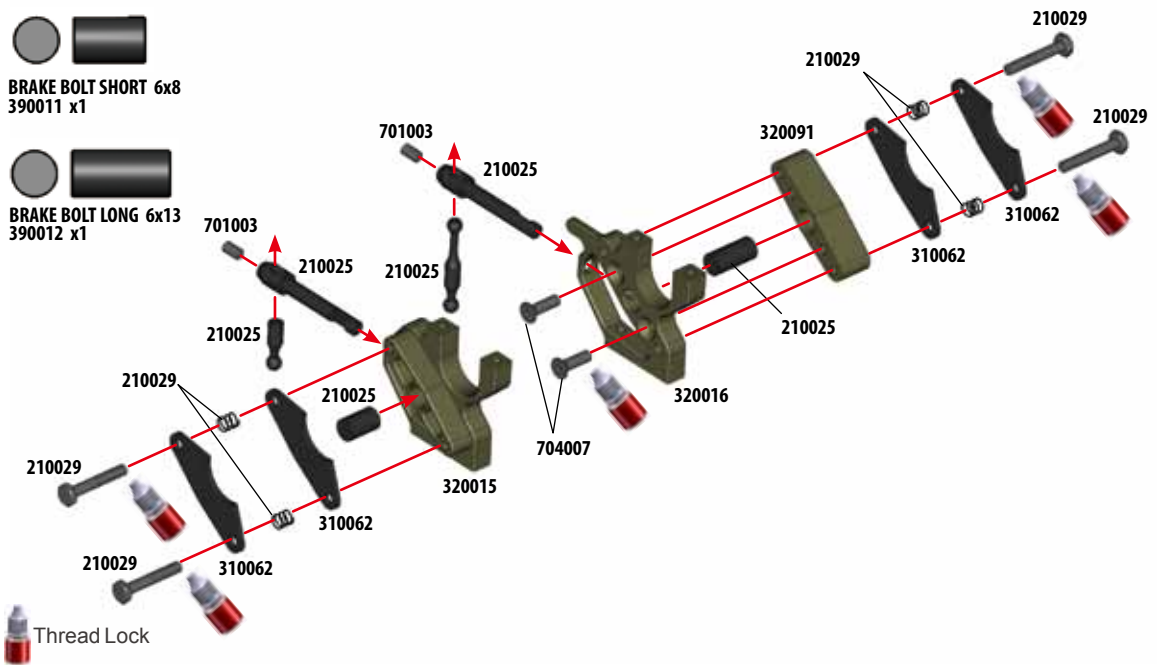

Thread Lock

39



TIE ROD 18MM
330113 x1



BH M3x6
705001 x2



BH M3x8
705002 x4

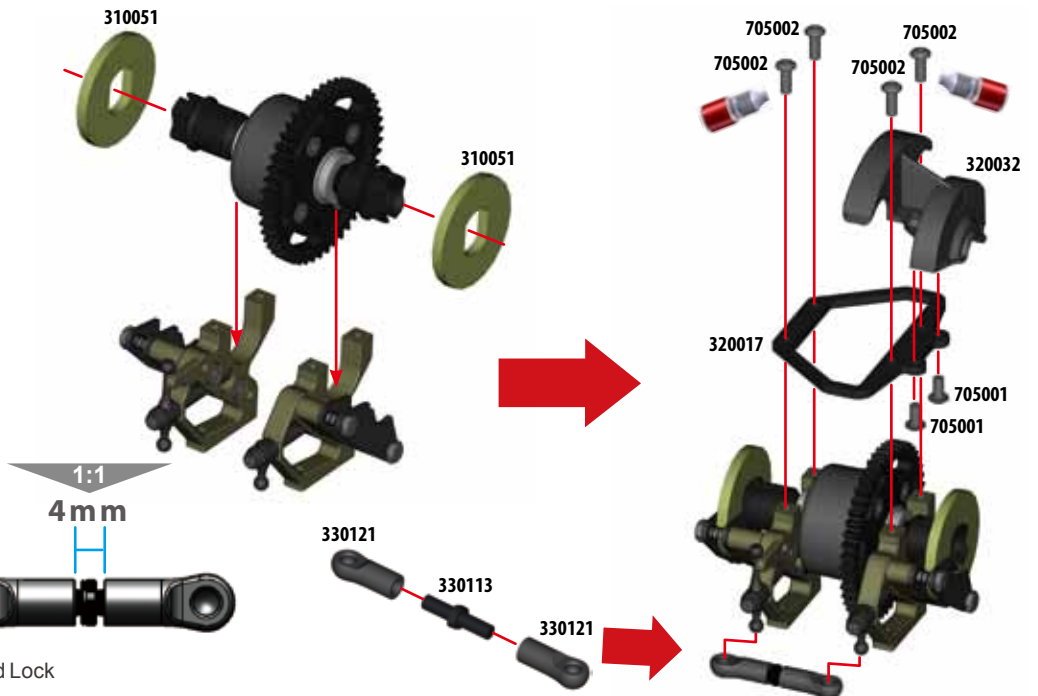

Thread Lock

40



CS M3x6
704004 x4

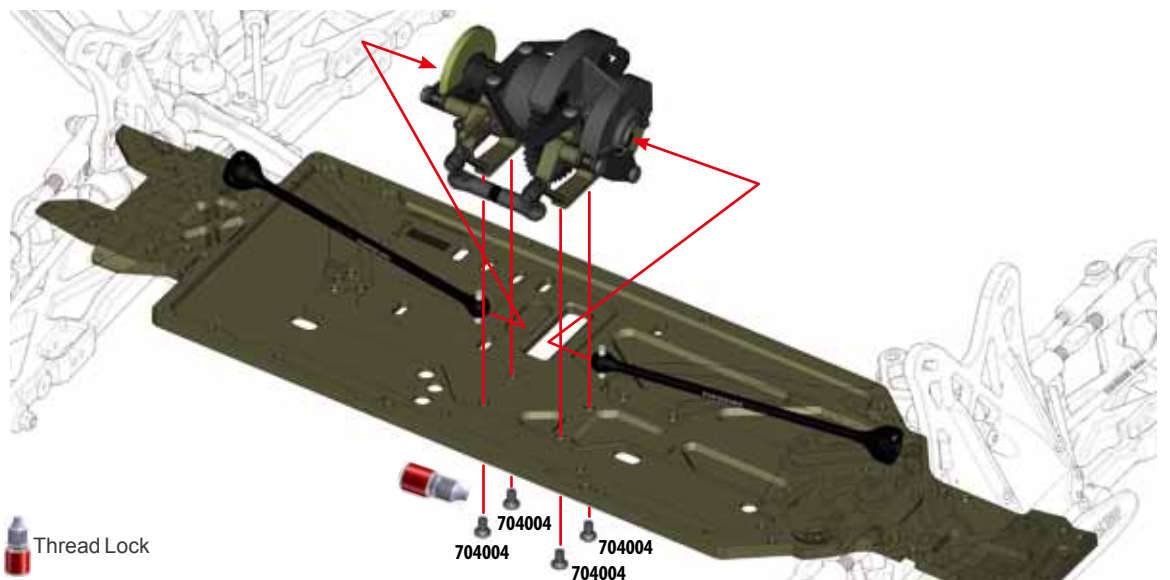

Thread Lock

41



SHOCK PISTON SHIM
330111 x4

SHOCK CAP-B
330083 x4

BH M2.5X8
705016 x4

Note: Make 2 Front and 2 Rear

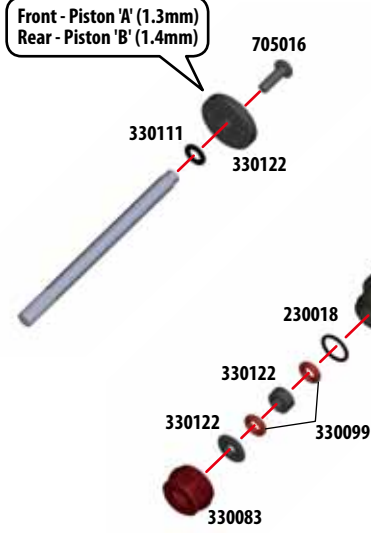

Front
330080 x2



Rear
330084 x2



Front 330110 x2



Rear 330112 x2



42

Front



Rear

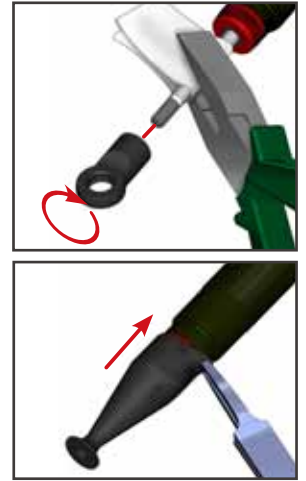
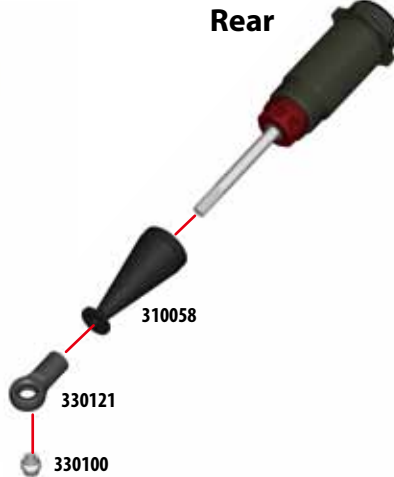

43

SHOCK CAP-A
330081 x4

SHOCK PRELOAD NUT
330082 x4

Shock Oil
600CST # TD390045

Note: Make 2 Front and 2 Rear

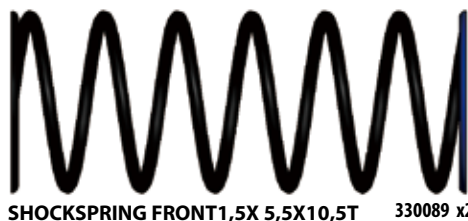
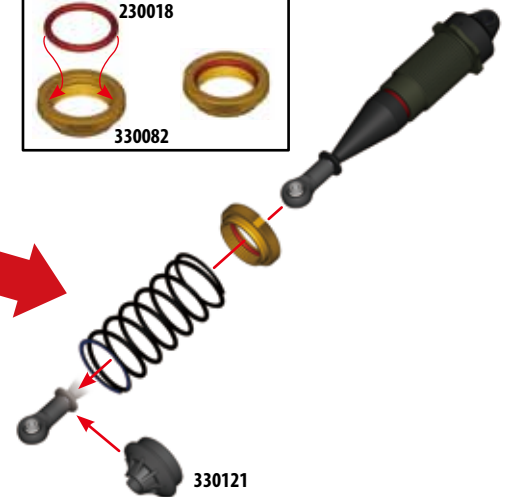
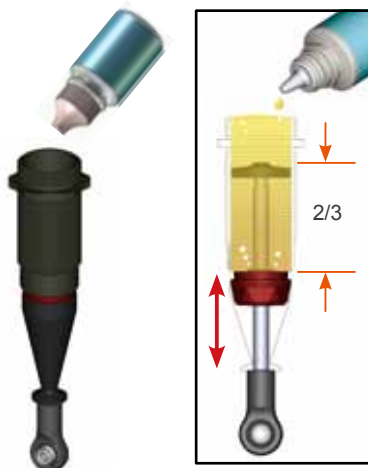

SHOCKSPRING FRONT1,5X 5,5X10,5T 330089 x2

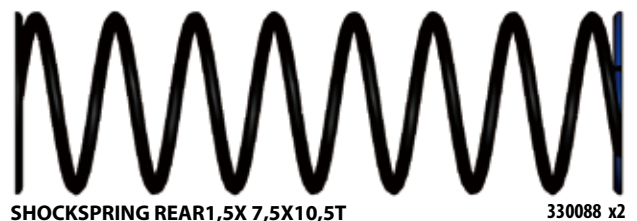

SHOCKSPRING REAR1,5X 7,5X10,5T 330088 x2

44

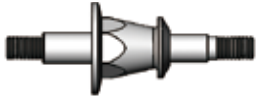

SHOCK MOUNT
330101 x2



BH M3x16
705015 x2



PIVOT BALL BUSHING
712002 x2



NUT M3 high
715002 x4

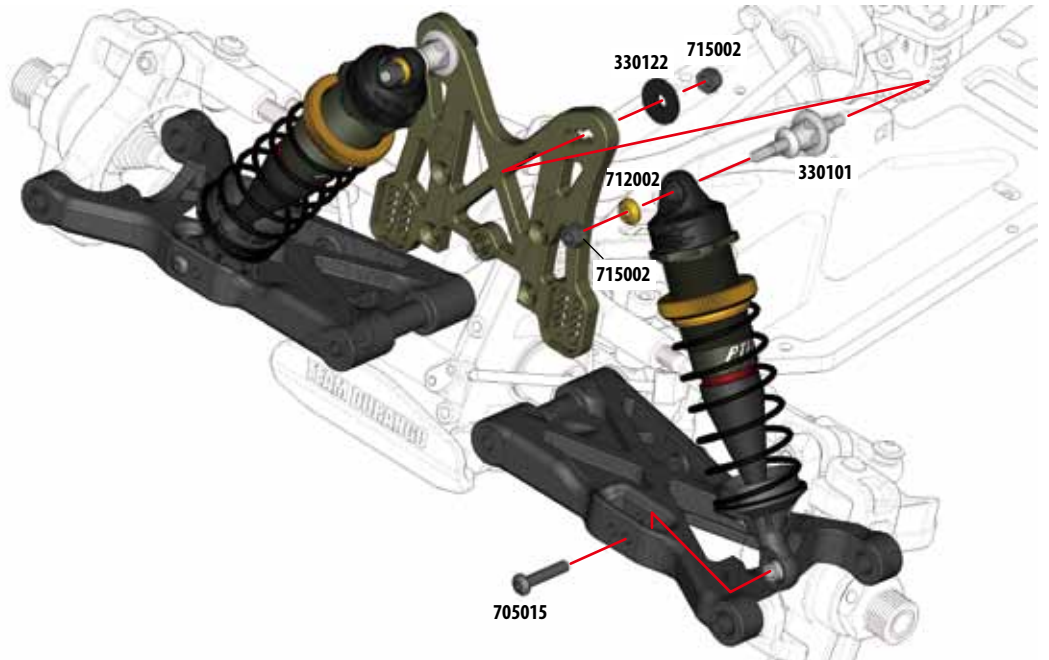

45



SHOCK MOUNT
330101 x2



BH M3x16
705015 x2



PIVOT BALL BUSHING
712002 x2



NUT M3 high
715002 x4

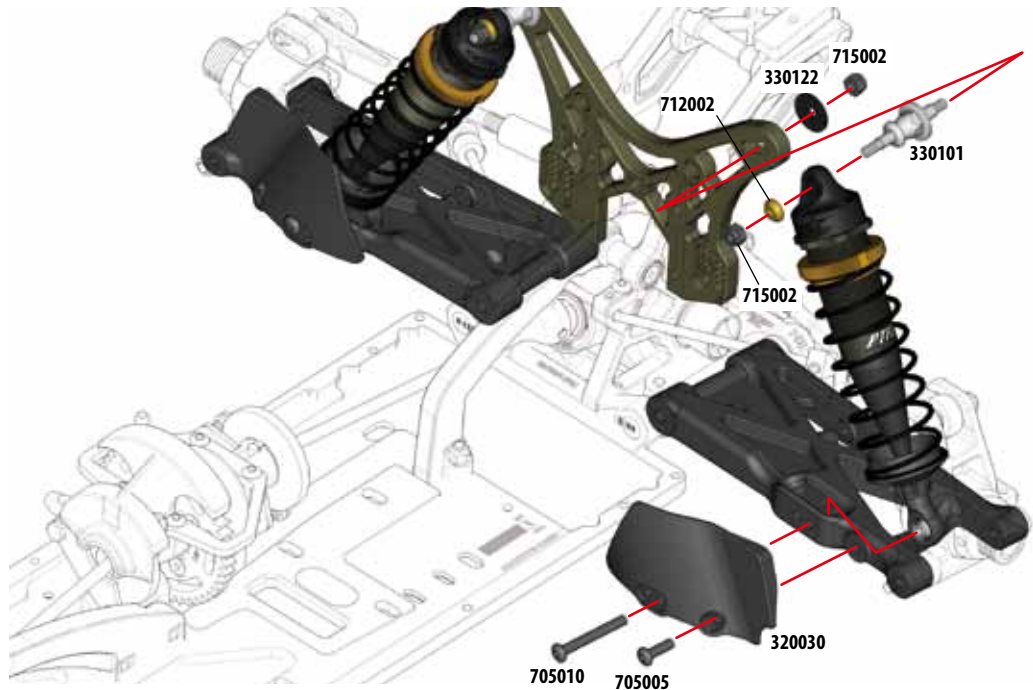

46

BAG

K

1:1



BH M3x6
705001 x8

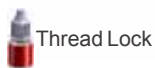
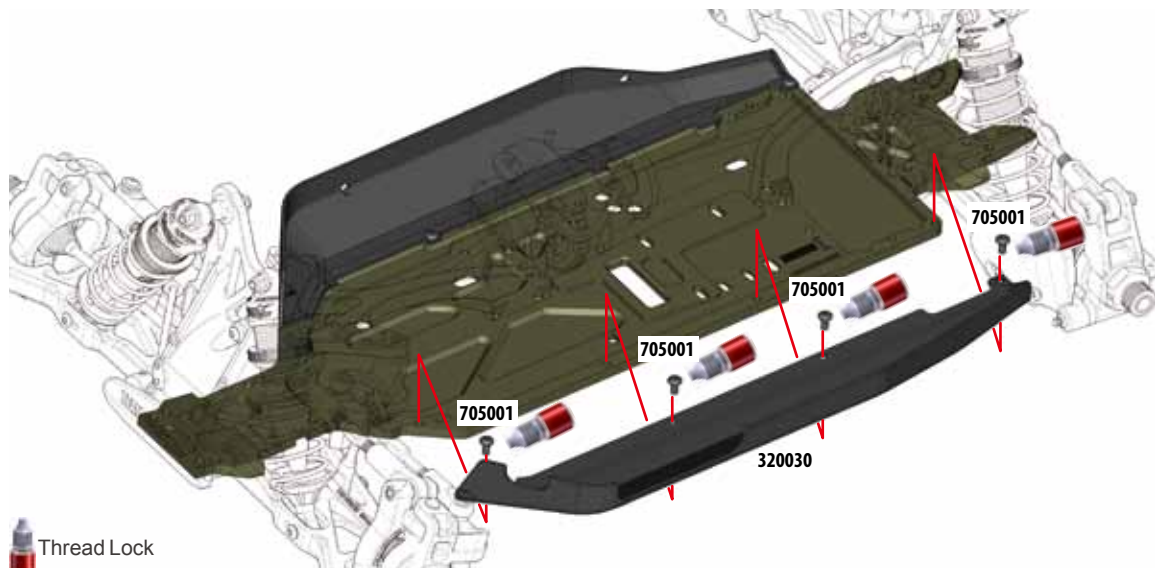

47



BH M3x10
705005 x8



SERVO SHIM
709007 x8

Throttle Servo

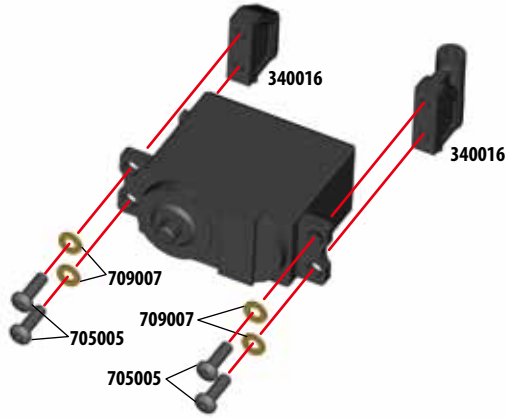

Steering Servo

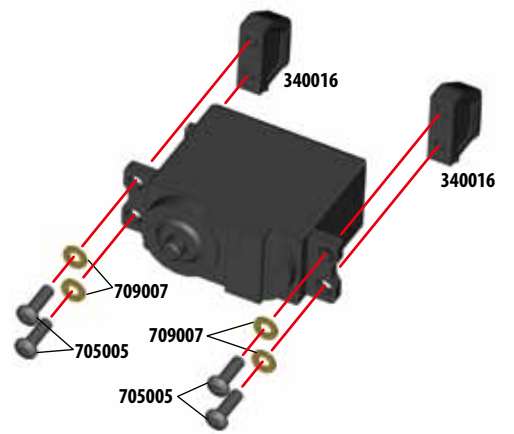

48



BH M3x10
705005 x4

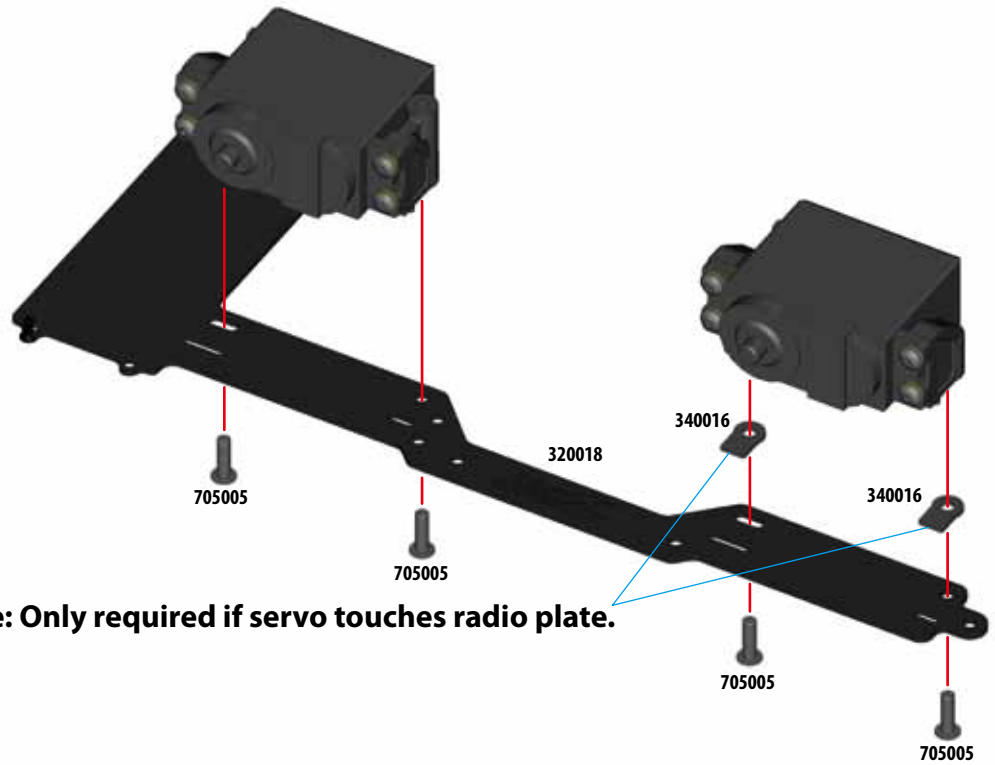

Note: Only required if servo touches radio plate.

49



M2x10

M2x10

320032

290009



50

SETScrew M3x4
701002 x1

CS M2x5
704046 x4

BH M3x6
705001 x2

BH M3x10
705005 x2

BH M3x5
705006 x2

BH M3x16
705015 x1

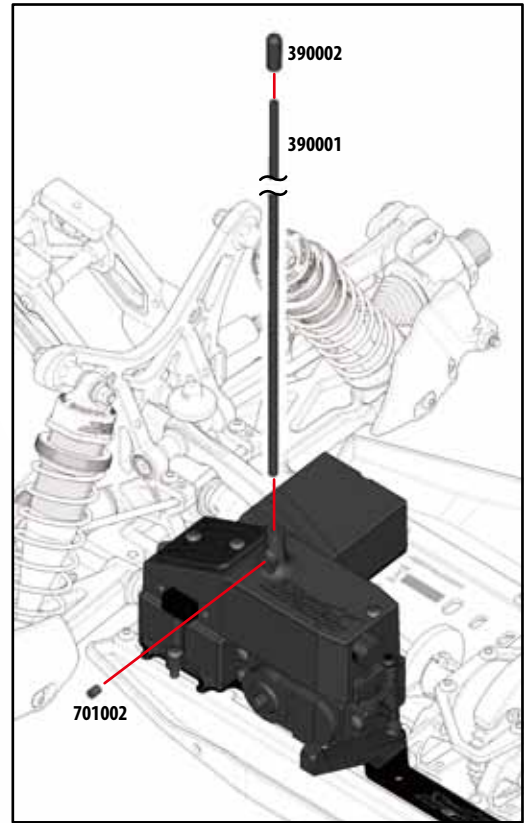
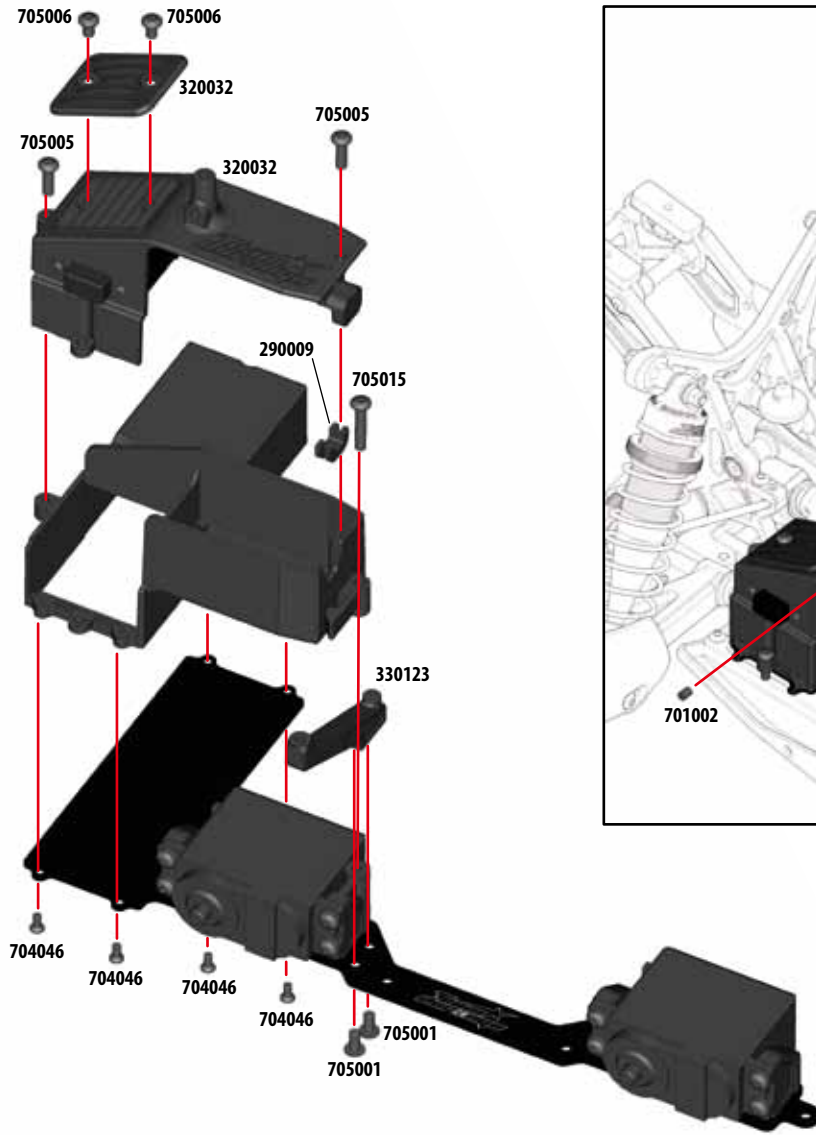

51

BH M3x10
705005 x2

BH M3x5
705006 x1

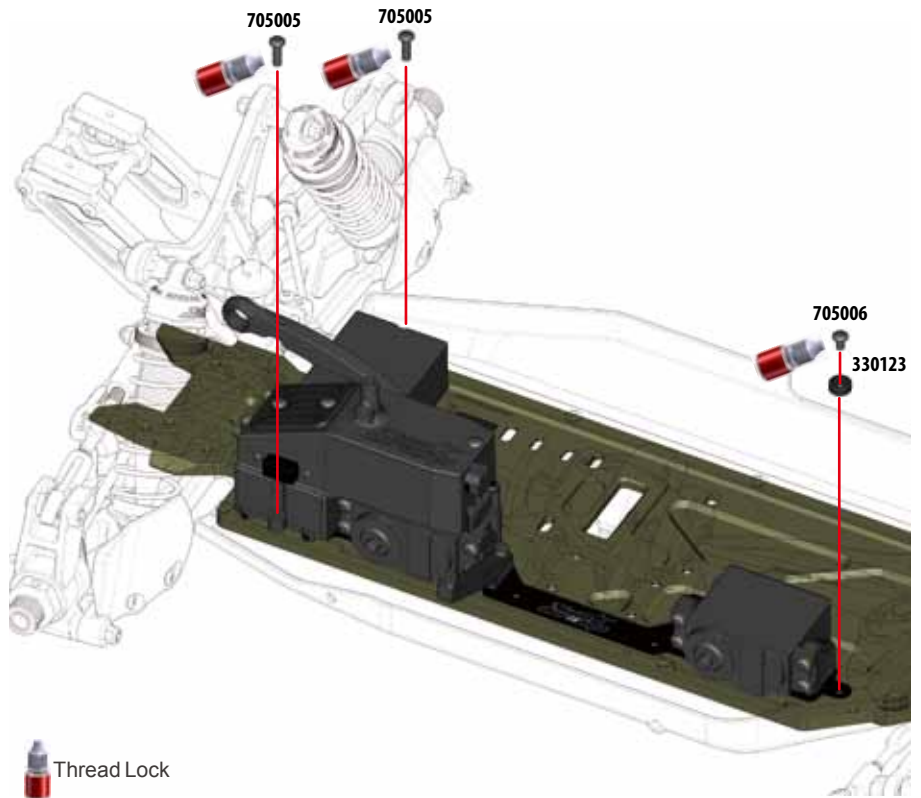
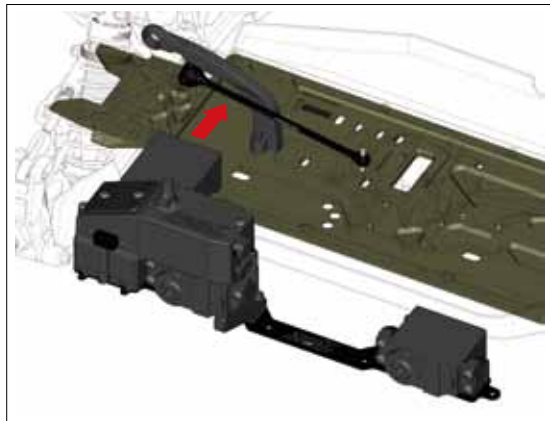

Thread Lock

52



SH M2.5x6mm
704019 x3

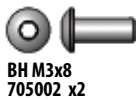

BH M3x8
705002 x2

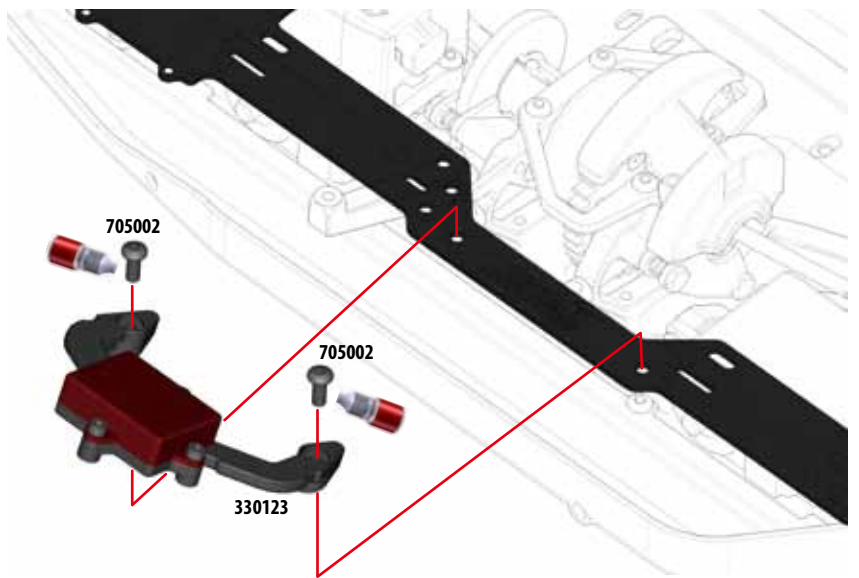
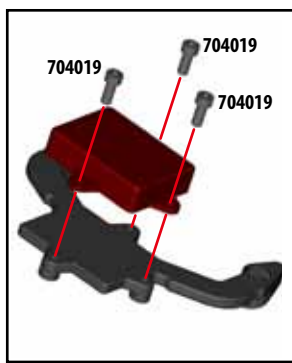

Thread Lock

53

BAG

L

1:1



CLUTCH NUT
270002 x1



CLUTCH SHOE
310161 x3



BALL BEARING FOR CLUTCH
601002 x2



SH M3x10
704009 x4



BH M3x10
705005 x1



CLUTCH SHOE SHIM
709019 x3



DISTANCE SHIM
709015 x9



Thread Lock



CLUTCH SPRING
310159 x3

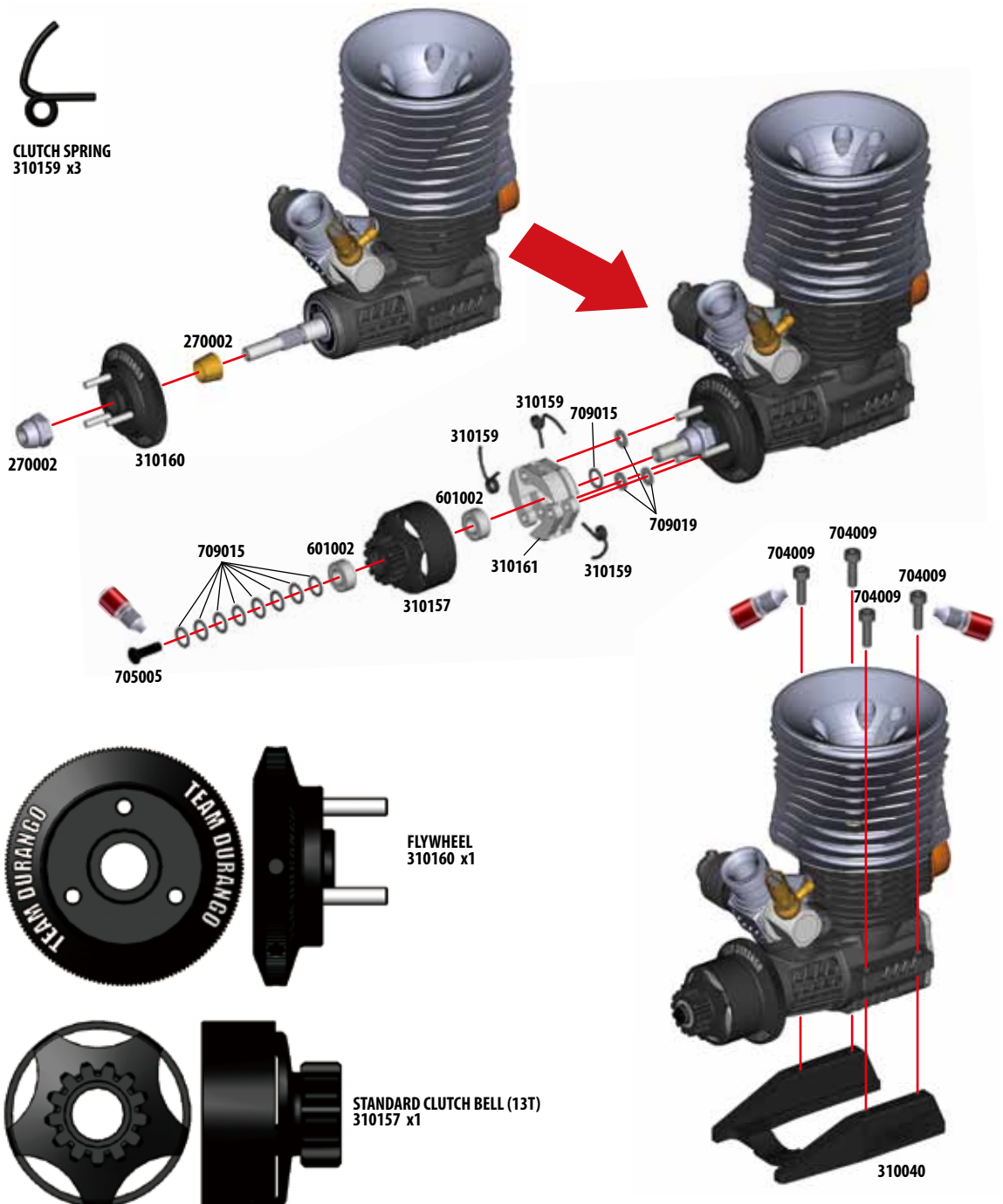

54

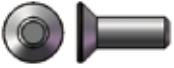

CS M4x12
704037 x4



BH M3x5
705006 x2



ENGINE MOUNT SHIM
709020 x4

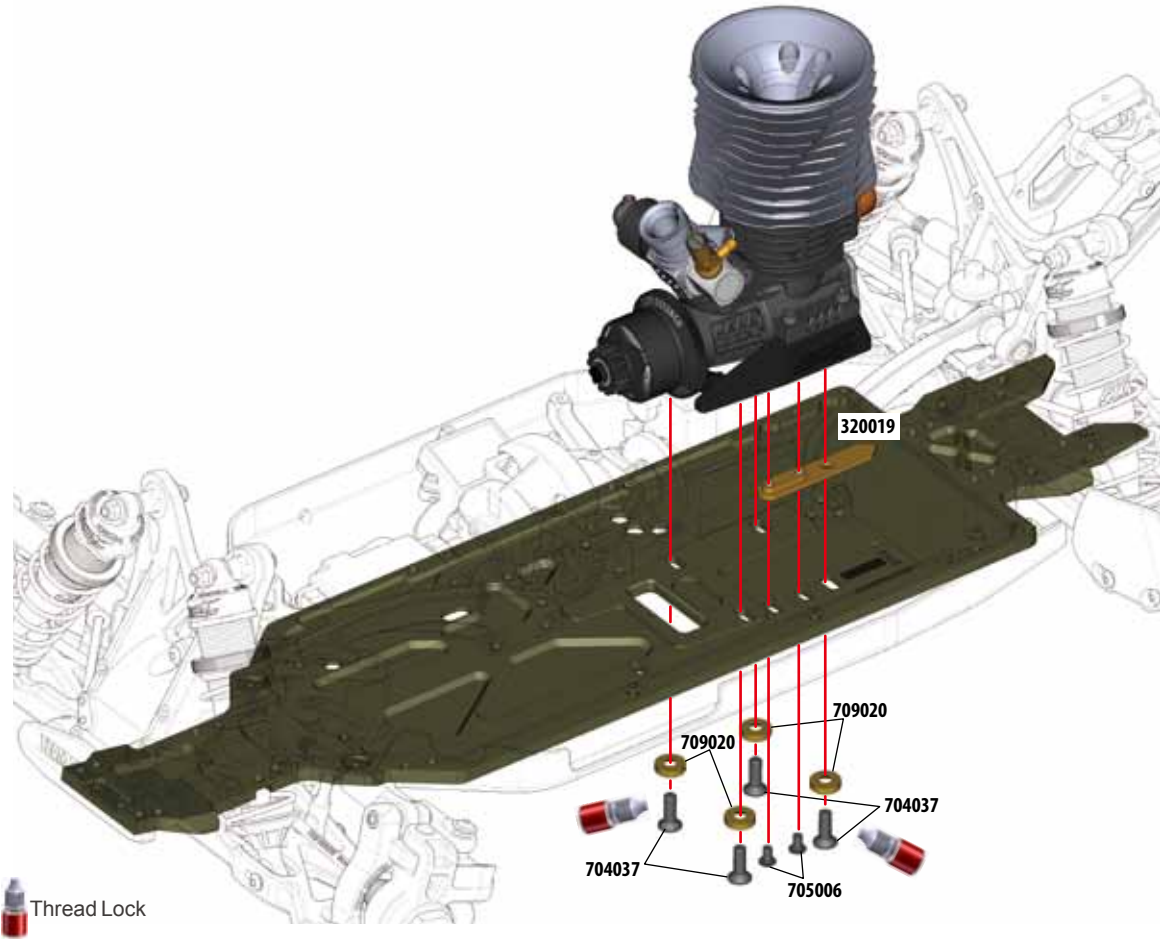

Thread Lock

55

BAG

M

1:1



FUEL TANK BUSHING INSERT
270003 x2



FUEL TANK BUSHING
270003 x2



CS M3x12
704003 x1



CS M3x20
704014 x1



BH M3x6
705001 x4



BH M3x8
705002 x1

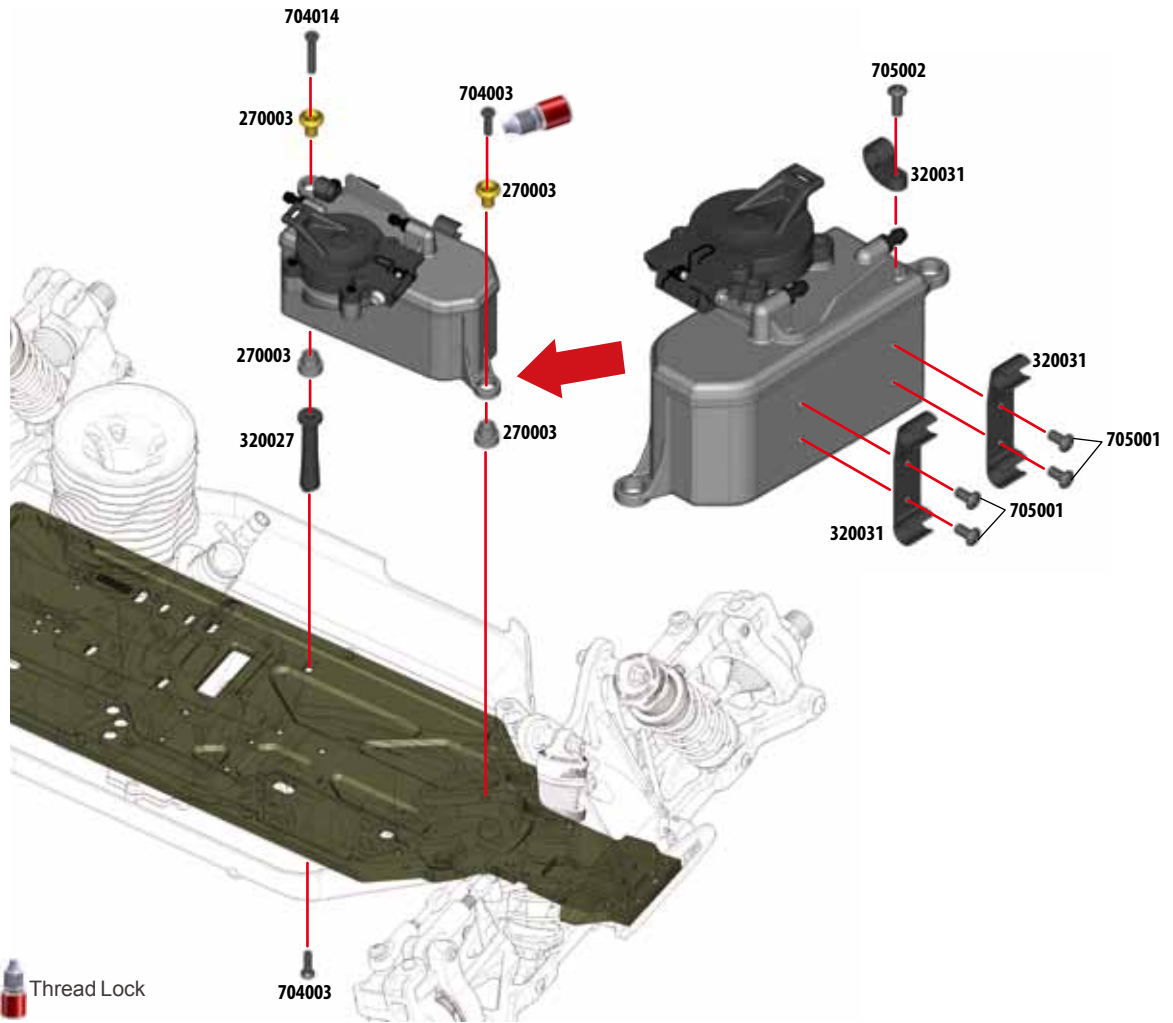

Thread Lock

56



MUFFLER SPRING HOLDER
290006 x1



MUFFLER SPRING
290006 x1



SETSCREW M4x5
701009 x1



SH M3x5
704026 x1

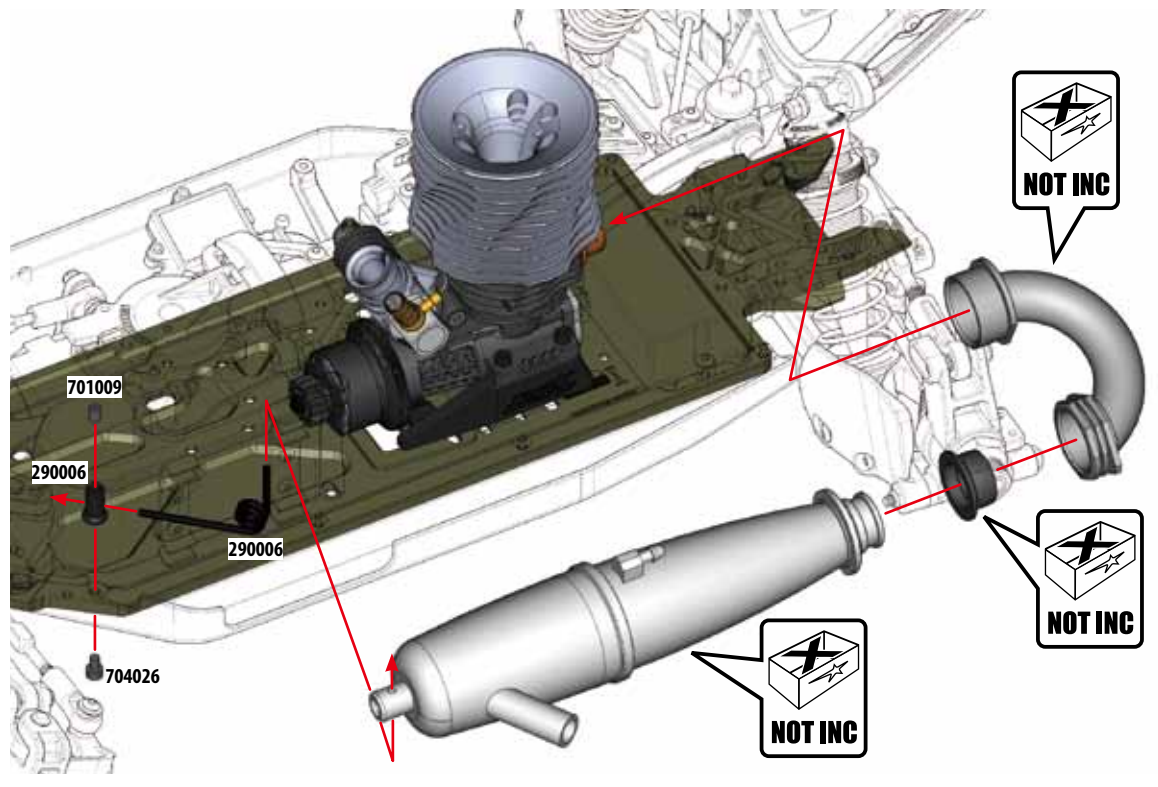

57

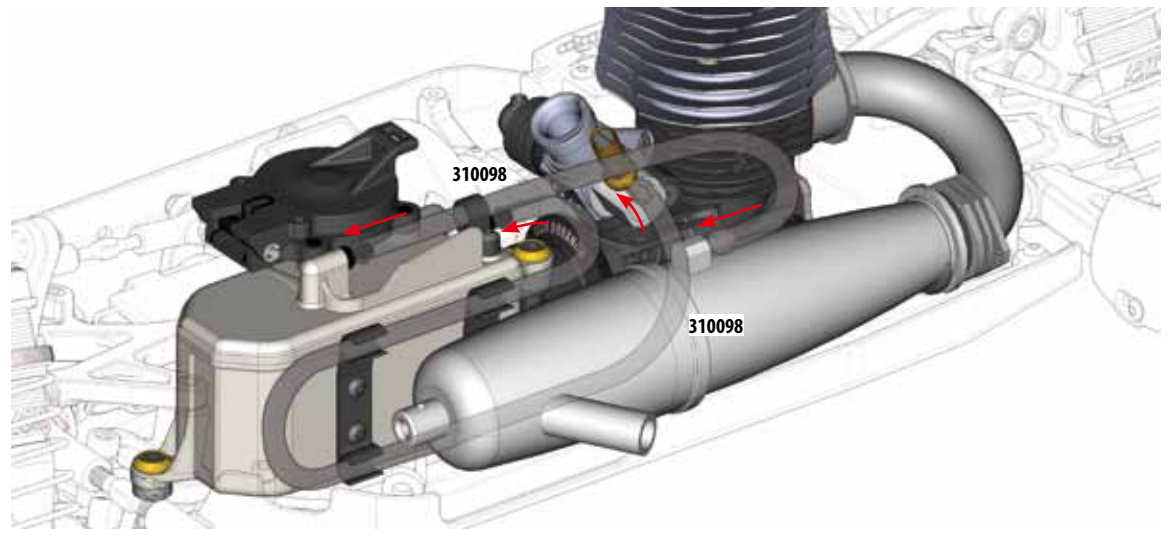

58



330073 x2



BH M3x18
705012 x1



SHIM A-TYPE
709011 x1



NUT M3 high
715002 x1

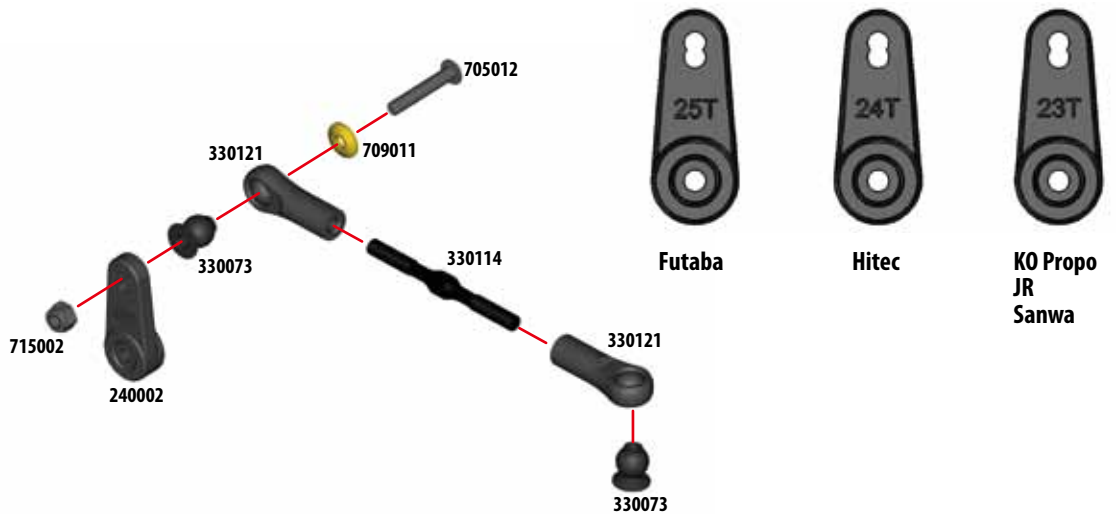

59

BH M3x6
705001 x1

BH M3x16
705015 x1

SHIM A-TYPE
709011 x1

NUT M3 high
715002 x1

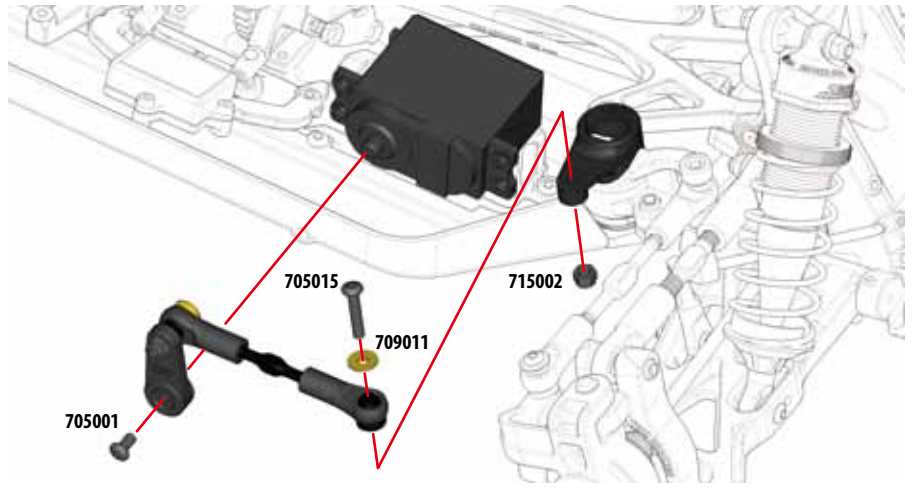

60

PIVOTBALL E-TYPE LONG
330109 x2

PIVOTBALL J-TYPE
330116 x1

PIVOTBALL I-TYPE
330115 x1

SERVO SHIM
709007 x2

NUT M3 high
715002 x2

TIE ROD 33mm
330108 x1

THROTTLE TIE ROD 54.7mm
310071 x1

BRAKE TIE ROD 74.7mm
310070 x1



Futaba



Hitec



KO Propo
JR
Sanwa

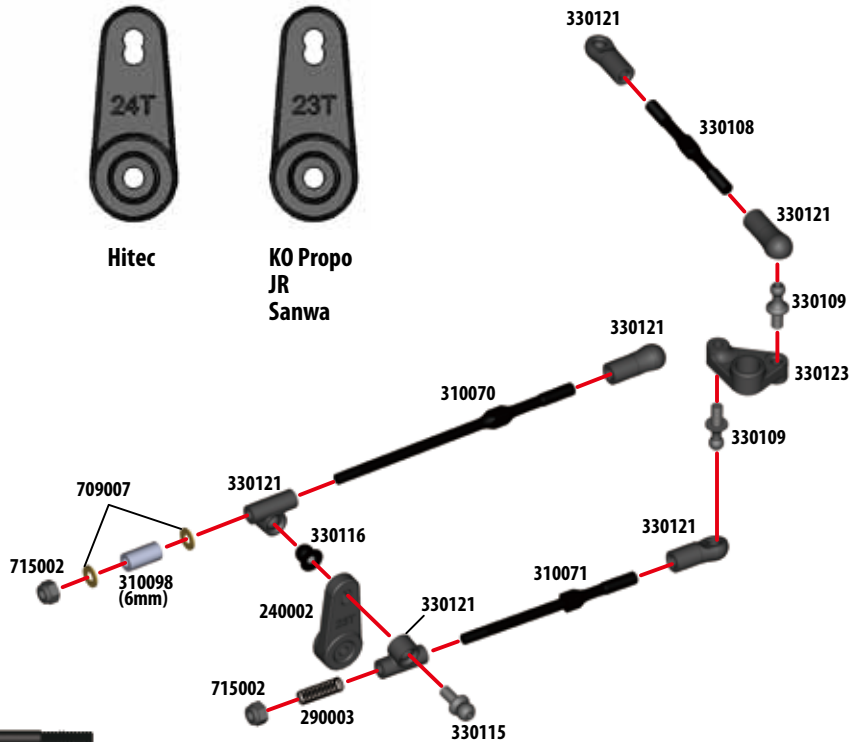

61

THROTTLE LINK BUSHING
290003 x1

BALL BEARING FLANGED FOR
THROTTLE LINK
602002 x2

BH M3x6
705001 x1

BH M3x16
705015 x1

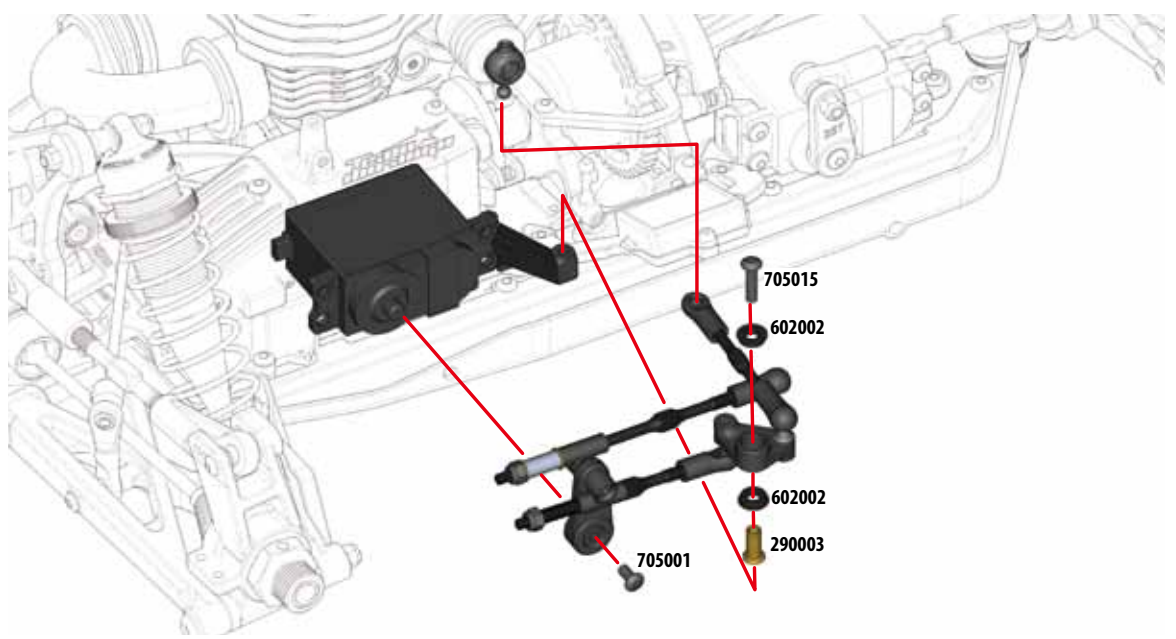

62

BAG

N

1:1



CS M3x12
704003 x2

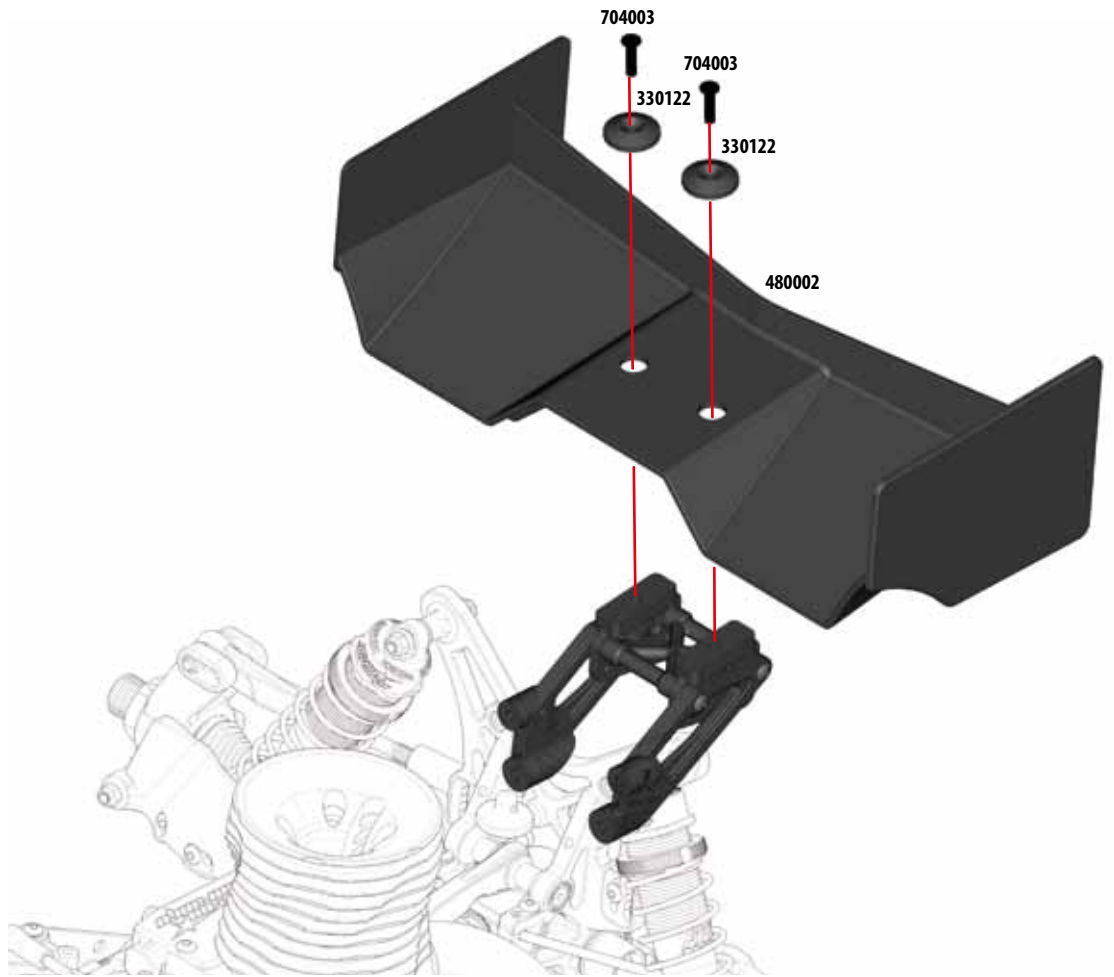

63



WHEELNUT
310043 x4

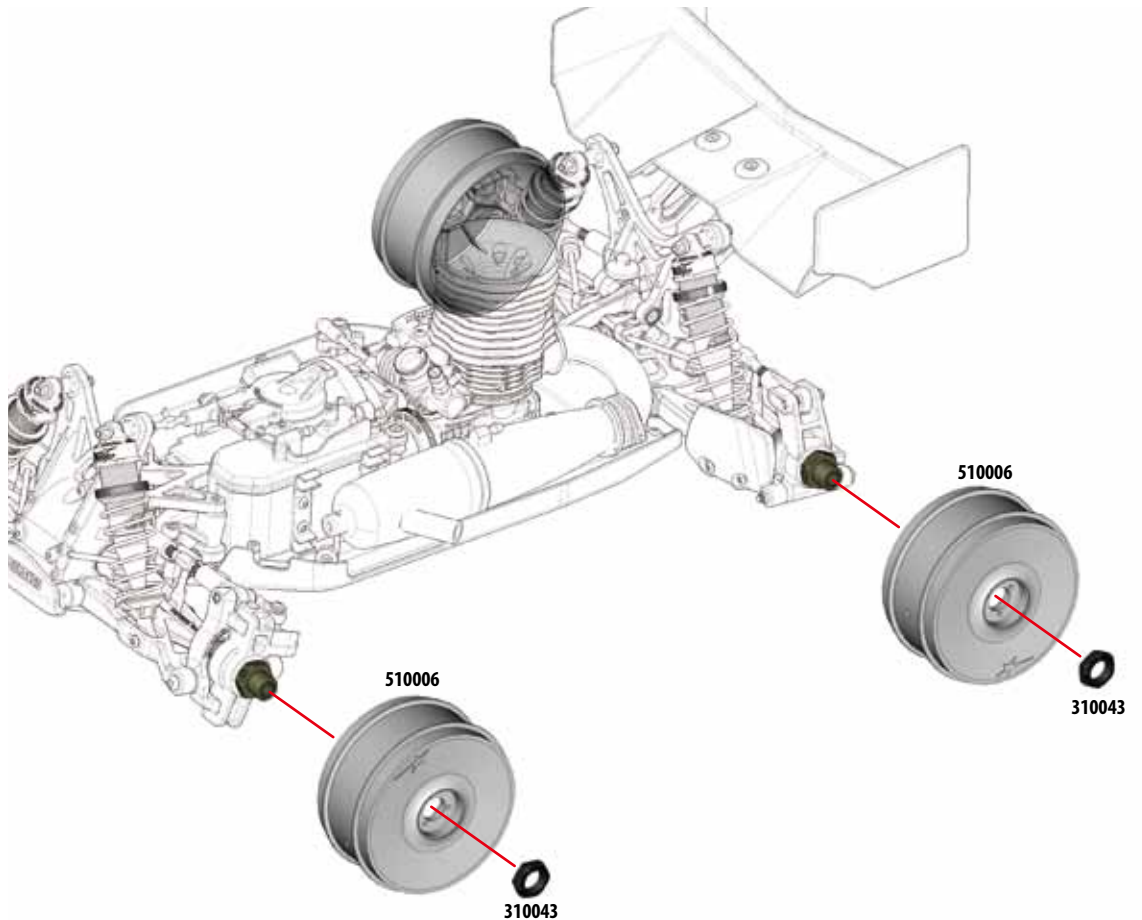

64



CS M3x8
704006 x1

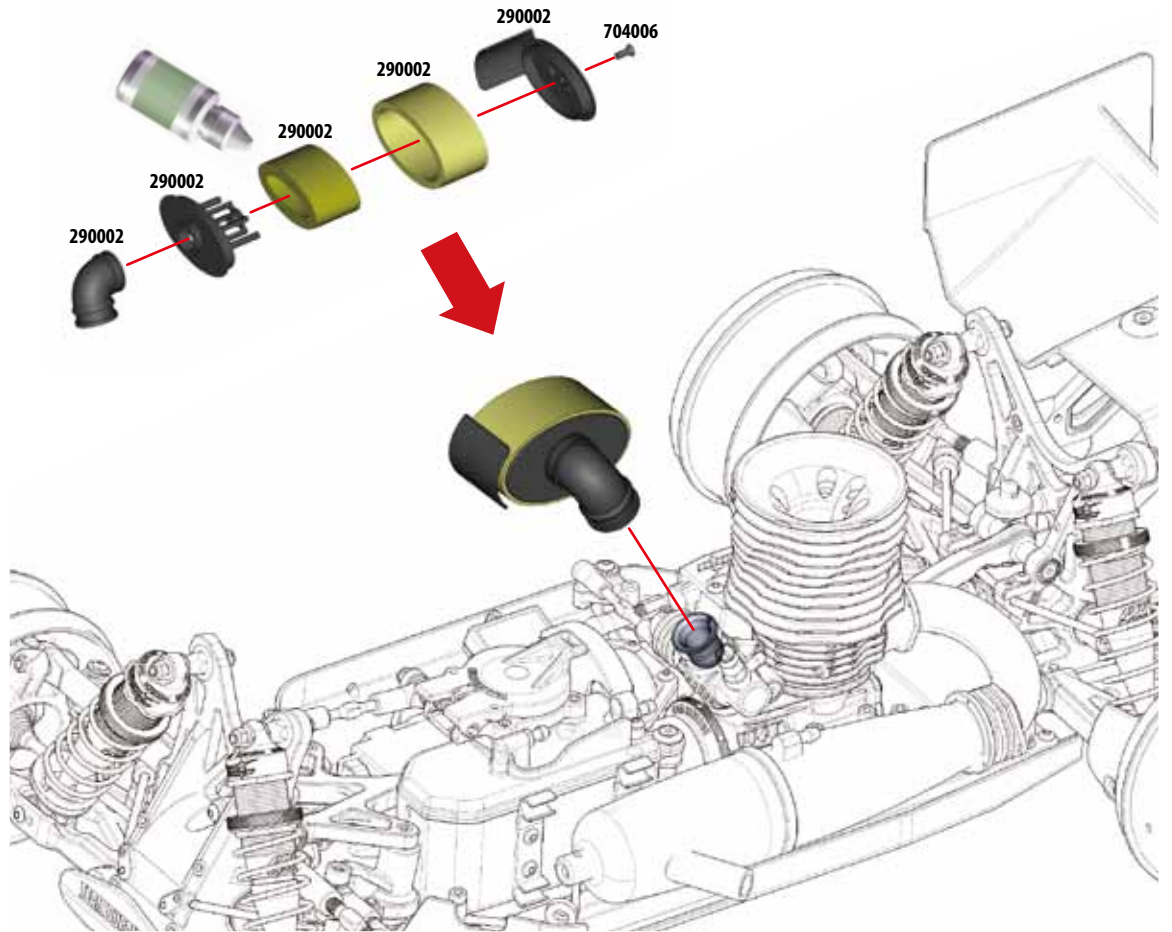

Air Filter Oil

65



SNAP PIN 4mm
390007 x2

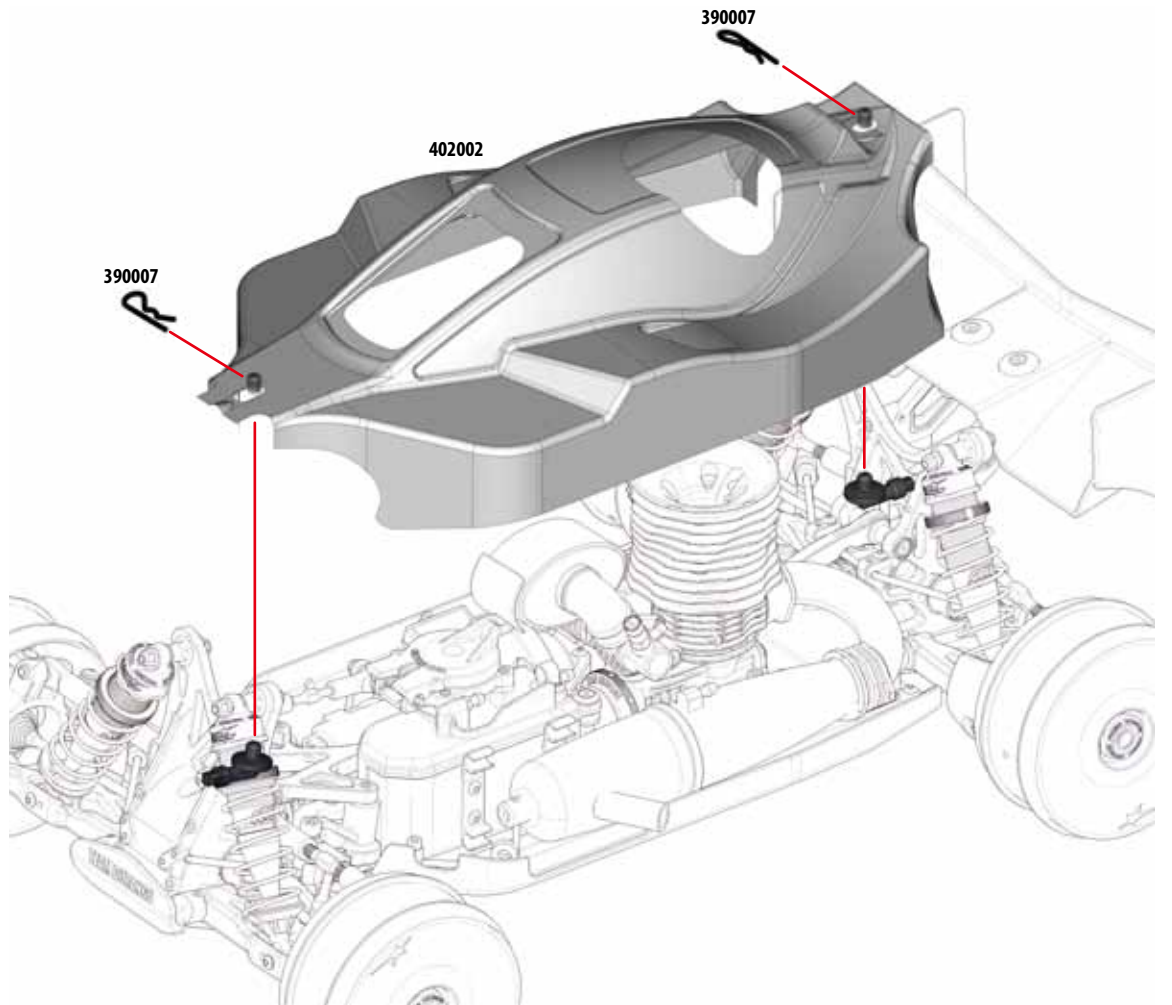

TEAM DURANGO DNX408

SETUP SHEET

NAME NOM NAME DATE DATUM DATE **SETUPBLATT FICHE DE RÉGLAGE V1.0 E**

EVENT VERANSTALTUNG EVENTMENT TRACK STRECKE PISTE AIR TEMP UMLIEGUNGSTEMP. TEMPÉRATURE DE L'AIR

TRACK SIZE STRECKENGRÖSSE TAILLE DE LA PISTE SURFACE STRECKENBELAG TYPE DE SURFACE TRACTION LEVEL GRIF ADHÉRENCE CONDITIONS WETTER NIVEAU D'HYDROMÉTRIE

RIDE HEIGHT BODENFREIHEIT GARDE AU SOL

CAMBER ANGLE STURZ ANGLE DE CARROSSAGE

TOE IN/OUT VORSUR/NACHSPUR ANGLE DE PINCEMENT

DIFF. OIL DIFF. ÖL HUILE DE DIFF. cst

SWAY BAR STABILISATOR BARRE ANTI-ROULIS mm

SWAY BAR LINK STABILISATOR FÉRIEUNKE ATTACHE DE LA BARRE ANTI-ROULIS mm

WISHBONE DROOP AUSRÜCKUNG ARSE DROOP DES TRIANGLE ARRIÈRES

NOTES NOTIZEN REMARQUES

FRONT VORN AVANT

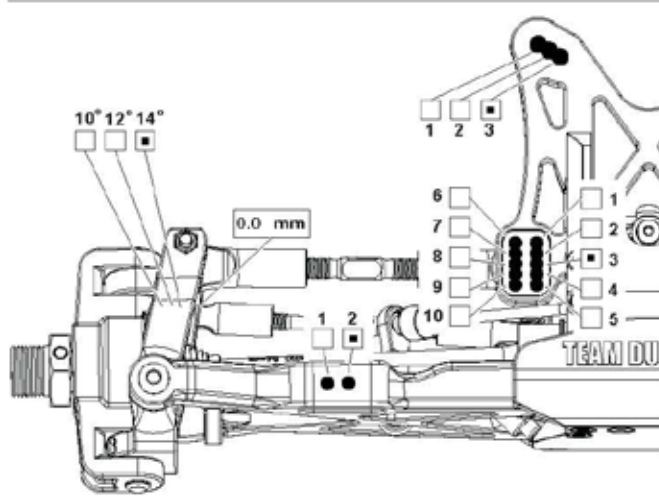

FRONT SHOCKS VORNE DÄMPFER AVANT AMORTISSEURS

SPRINGS FEDERN RESSORTS

REBOUND REBOUND REBOND %

PRELOAD FEDERVORSpanNING PRÉCONTRAINTE mm

OIL WT. ÖL/SKOSITÄT GRADE HUILE cst

PISTON KOLBEN PISTON

LENGTH LANGE LONGUEUR

NOTES NOTIZEN REMARQUES

RIDE HEIGHT BODENFREIHEIT GARDE AU SOL

CAMBER ANGLE STURZ ANGLE DE CARROSSAGE

DIFF. OIL DIFF. ÖL HUILE DE DIFF. cst

SWAY BAR STABILISATOR BARRE ANTI-ROULIS mm

SWAY BAR LINK STABILISATOR FÉRIEUNKE ATTACHE DE LA BARRE ANTI-ROULIS mm

WISHBONE DROOP AUSRÜCKUNG ARSE DROOP DES TRIANGLE ARRIÈRES

NOTES NOTIZEN REMARQUES

REAR HINTEN ARRIÈRE

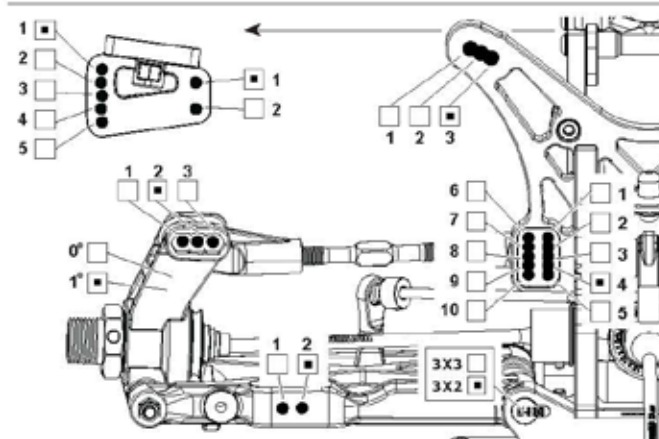

REAR SHOCKS HINTEN DÄMPFER ARRIÈRE AMORTISSEURS

SPRINGS FEDERN RESSORTS

REBOUND REBOUND REBOND %

PRELOAD FEDERVORSpanNING PRÉCONTRAINTE mm

OIL WT. ÖL/SKOSITÄT GRADE HUILE cst

PISTON KOLBEN PISTON

LENGTH LANGE LONGUEUR mm

NOTES NOTIZEN REMARQUES

ENGINE MASCHINE MOTEUR

GEAR RATIO UNTERSATZUNG RAPPORT D'ENGRENAGE

CLUTCH SPRING KUPPLUNGSSFEDE RESSORT D'EMBRAYAGE

CLUTCH SHOE KUPPLUNGSSCHUHE MASSELOTE D'EMBRAYAGE

MANIFOLD KRÜMMER PIPE D'ÉCHAPPEMENT

MUFFLER RESO ROHR SILENCIEUX

PLUG ZÜNDKERZE BOULGIE

FUEL KRAFTSTOFF CARBURANT

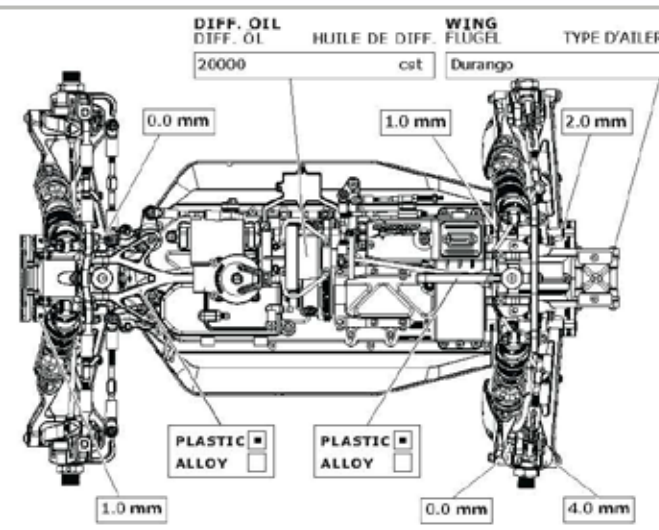

TYRES REIFEN PNEUS

FRONT	REAR	
BRAND	HERSTELLER	MARQUE
<input type="text" value="Proline"/>	<input type="text" value="Proline"/>	
TREAD	PROFIL	PROFIL
<input type="text" value="Caliber"/>	<input type="text" value="Caliber"/>	
COMPOUND	MISCHUNG	DURETÉ
<input type="text" value="M3"/>	<input type="text" value="M3"/>	
INSERT	EINLAGEN	MOUSSE
<input type="text" value="Standard Blue"/>	<input type="text" value="Standard Blue"/>	
WHEEL	FELGE	JANTE
<input type="text" value="Proline"/>	<input type="text" value="Proline"/>	
NOTES	NOTIZEN	REMARQUES
<input type="text"/>	<input type="text"/>	<input type="text"/>

RESULTS PLATZIERUNG RÉSULTAT QUALIFYING POSITION QUALIFIKATIONS POSITION FINAL POSITION ENDPLATZIERUNG POSITION FINALE

AVERAGE LAP DURSCHRITTSZEIT TEMPS AU TOUR MOYEN BEST LAP SCHRÄLLESTE MIN DE MEILLEUR TEMPS AU TOUR RACE TIME REINHAUER DURÉE DE LA COURSE



www.team-durango.com © Team Durango Ltd. 2010

Further set-ups can be found online @: <http://www.team-durango.com/in-the-pits.php>

TEAM DURANGO DNX408

SETUP SHEET

NAME NOM: Kevin Brunson DATE DATUM: _____ SETUP BLATT FICHE DE RÉGLAGE V1.0 E

EVENT VERANSTALTUNG: Proline International TRACK STRECKE: Slough AIR TEMP LUFTTEMPERATUR: 22°C

TRACK SIZE STRICKENGRÖSSE: Large SURFACE STRICKENBELAG: Dirt TRACTION LEVEL GRIFFF: High CONDITIONS WETTER: Dry

RIDE HEIGHT (BODENFREIHEIT) GARDE AU SOL: 26 mm

CAMBER ANGLE (STURZ) ANGLE DE CAPROSSAGE: 2°

TOE IN/OUT (VOESPUR/NACHSPUR) ANGLE DE PERÇEMENT: +/- 0

DIFF. OIL (DIFF. ÖL) HUILE DE DIFF.: 5000 cst

SWAY BAR (STABILISATOR) BARRE ANTI-ROULIS: 2.1 mm

SWAY BAR LINK (STABILISATOR BELEGANG) ATTACHE DE LA BARRE ANTI-ROULIS: 1 mm

WISHBONE DROOP (ARSTEDERMS) ICISE DROOP LES TRIANGLES ARRIÈRES: 1 mm

NOTES (NOTIZEN) REMARQUES: Droop screw to chassis 1mm

FRONT VORN AVANT

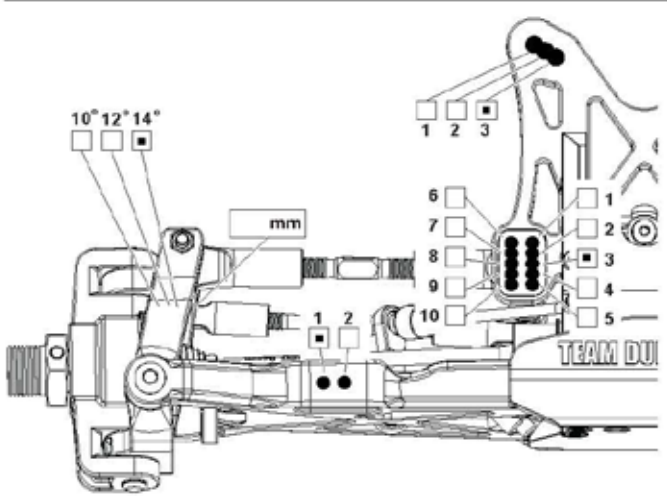

FRONT SHOCKS VORNE DÄMPFER AVANT AMORTISSEURS

SPRINGS (FEDERN) RESSORTS: Black

REBOUND (REBOUND) REBOND: 0 %

PRELOAD (FEDERTORSION) PRÉCONTRAINTE: 6 mm

OIL WT. (ÖLVIŠKOSITÄT) GRADE HUILE: 600 cst

PISTON (KOLBEN) PISTON: 1.2 8 hole

LENGTH (LANGE) LONGUEUR: 29 mm

NOTES (NOTIZEN) REMARQUES:

RIDE HEIGHT (BODENFREIHEIT) GARDE AU SOL: 27 mm

CAMBER ANGLE (STURZ) ANGLE DE CORROSSAGE: 3°

DIFF. OIL (DIFF. ÖL) HUILE DE DIFF.: 2000 cst

SWAY BAR (STABILISATOR) BARRE ANTI-ROULIS: 2.5 mm

SWAY BAR LINK (STABILISATOR BELEGANG) ATTACHE DE LA BARRE ANTI-ROULIS: 0 mm

WISHBONE DROOP (ARSTEDERMS) ICISE DROOP LES TRIANGLES ARRIÈRES: 1 mm

NOTES (NOTIZEN) REMARQUES:

REAR HINTEN ARRIÈRE

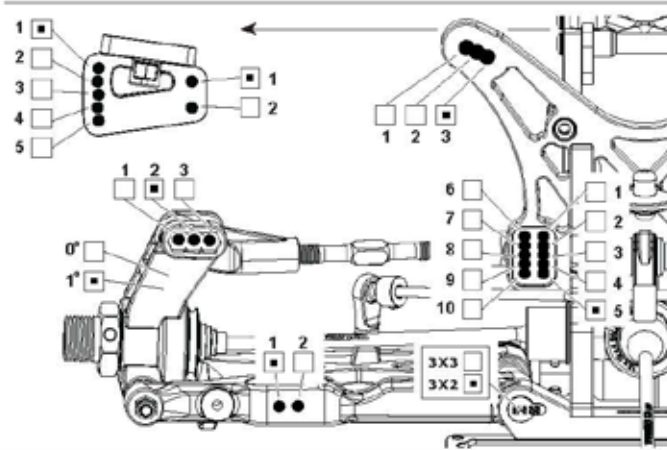

REAR SHOCKS HINTEN DÄMPFER ARRIÈRE AMORTISSEURS

SPRINGS (FEDERN) RESSORTS: Black

REBOUND (REBOUND) REBOND: 0 %

PRELOAD (FEDERTORSION) PRÉCONTRAINTE: 8 mm

OIL WT. (ÖLVIŠKOSITÄT) GRADE HUILE: 600 cst

PISTON (KOLBEN) PISTON: 1.2 8 hole

LENGTH (LANGE) LONGUEUR: 39 mm

NOTES (NOTIZEN) REMARQUES:

ENGINE (MASCHINE) MOTEUR: RB

GEAR RATIO (UNTERSATZUNG) RAPPORT D'ENGRENAGE: 14/48

CLUTCH SPRING (KUPPLUNGSPEDER) RESSORT D'EMBRAYAGE: 1.1 mm

CLUTCH SHOE (KUPPLUNGSBACKE) MASSELOTE D'EMBRAYAGE: K1 Alloy

MANIFOLD (KRUMMER) PIPE D'ÉCHAPPEMENT: RB01353-92P

MUFFLER (RESO ROHR) SILENCIEUX: 2045

PLUG (ZÜNDKERZE) BOUGIE: RB No6

FUEL (KRAFTSTOFF) CARBURANT: Byron

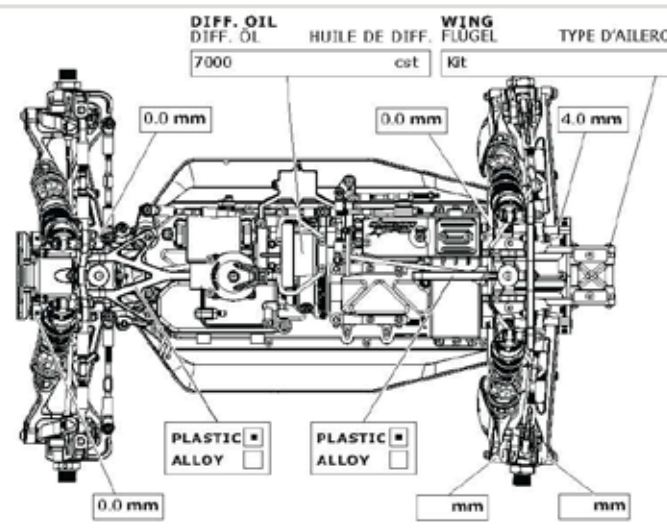

TYRES REIFEN PNEUS

FRONT	REAR	HERSTELLER	MARQUE
Proline	Proline	Proline	Proline
Caliber	Caliber	PROFIL	PROFIL
Compound	Mischung	DURETÉ	DURETÉ
M3	M3	MOUSSE	MOUSSE
Closed Cell Blue	Closed Cell Blue	WHEEL	FELGE
Proline V2	Proline V2	JANTE	JANTE
NOTES (NOTIZEN) REMARQUES:			

RESULTS PLATZIERUNG RÉSULTAT QUALIFYING POSITION (VORLAFFERENGS) POSITION DE QUALIFICATION: 6 FINAL POSITION (ENDPLATZIERUNG) POSITION FINALE: 2

AVERAGE LAP (DURCHSCHNITTZEIT) TEMPS AU TOUR MOYEN: 37 BEST LAP (SCHNELLSTE RANDE) MEILLEUR TEMPS AU TOUR: 35 RACE TIME (RENNDAUER) DURÉE DE LA COURSE: 1 Hour



Further set-ups can be found online @:<http://www.team-durango.com/in-the-pits.php>

TEAM DURANGO DNX408

SETUP SHEET

NAME ドライバー 姓名 DATE 日付 日期 セットアップシート 設定表 設定表 V1.0 A

EVENT イベント名 比賽項目 TRACK サーキット 跑馬場 AIR TEMP. 気温 温度

TRACK SIZE コースサイズ 場地面积 SURFACE 路面 地質 GRIP トラクションレベル 抓地力 CONDITIONS コンディション 天氣

RIDE HEIGHT 車高 車高 mm

CAMBER ANGLE キャンバー角 傾角 °

TOE IN/OUT トー角 東角 °

DIFF. OIL デフオイル 差速油 cst

SWAY BAR スタビライザー 防傾杆 mm

SWAY BAR LINK スタビライザーリンク 防傾連杆长度 mm

WISHBONE DROOP ドループ 尾搖臂下限 mm

NOTES メモ 備註

FRONT フロント 前 前

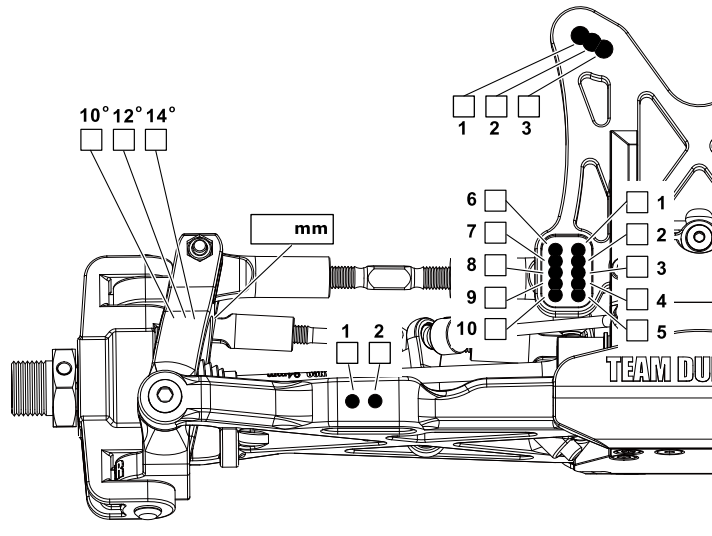

RIDE HEIGHT 車高 車高 mm

CAMBER ANGLE キャンバー角 傾角 °

DIFF. OIL デフオイル 差速油 cst

SWAY BAR スタビライザー 防傾杆 mm

SWAY BAR LINK スタビライザーリンク 防傾連杆长度 mm

WISHBONE DROOP ドループ 尾搖臂下限 mm

NOTES メモ 備註

REAR リア 后 后

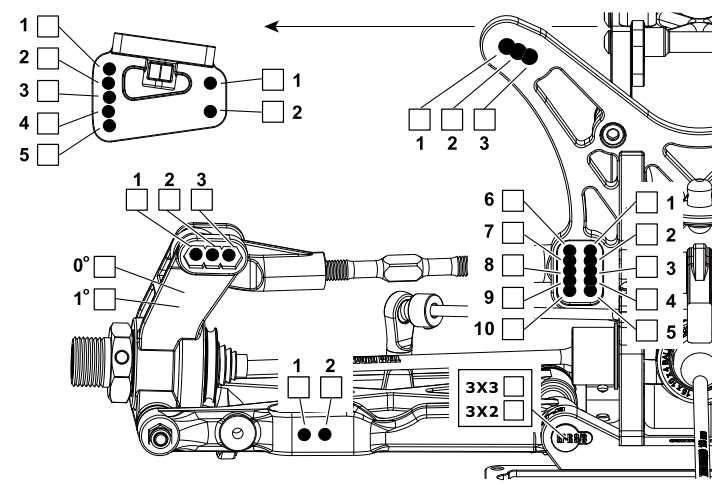

ENGINE エンジン 引擎 引擎

GEAR RATIO ギアレシオ 齒輪比

CLUTCH SPRING クラッチスプリング 甩片彈簧

CLUTCH SHOE クラッチシュー 甩片

MANIFOLD マニホールド 消音器

MUFFLER マフラー 排氣管

PLUG プラグ 火星塞

FUEL 燃料 燃料

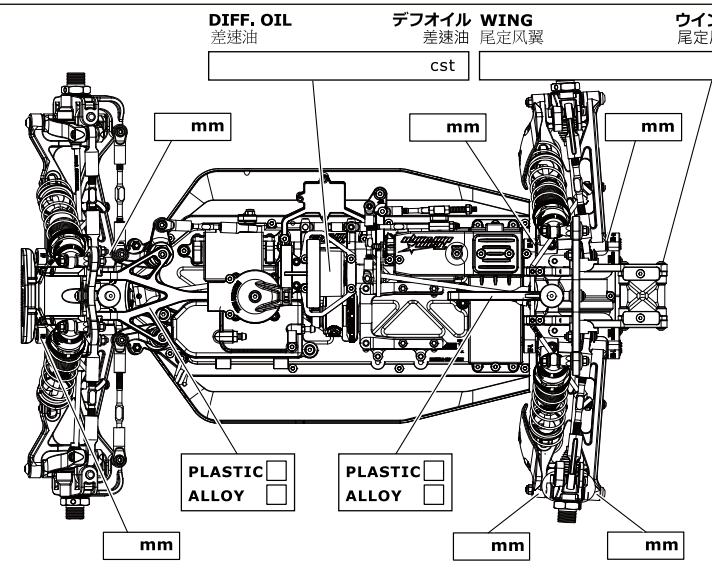

FRONT SHOCKS フロント ショック 前避震机

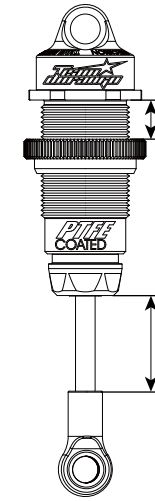

SPRINGS スプリング 彈簧

REBOUND リバウンド 回彈 %

PRELOAD プリロード 彈簧預壓 mm

OIL WT. ショックオイル 避震油 cst

PISTON ピストン

LENGTH シャフト長 长度 mm

NOTES メモ 備註

REAR SHOCKS リア ショック 后避震机

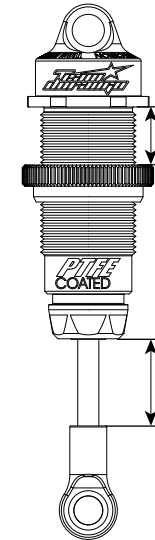

SPRINGS スプリング 彈簧

REBOUND リバウンド 回彈 %

PRELOAD プリロード 彈簧預壓 mm

OIL WT. ショックオイル 避震油 cst

PISTON ピストン

LENGTH シャフト長 长度 mm

NOTES メモ 備註

TYRES タイヤ 轮胎 輪胎

FRONT	REAR
BRAND ブランド 轮胎品牌	BRAND ブランド 轮胎品牌
TREAD トレッド 胎纹	TREAD トレッド 胎纹
COMPOUND コンパウンド 轮胎物料	COMPOUND コンパウンド 轮胎物料
INSERT インサート 胎胆	INSERT インサート 胎胆
WHEEL ホイール 轮圈	WHEEL ホイール 轮圈
NOTES メモ 备注	NOTES メモ 备注

RESULTS 結果 賽果 賽果

QUALIFYING POSITION 予選結果 預賽排名 預賽排名 **FINAL POSITION** 決勝結果 決賽排名 決賽排名

AVERAGE LAP 平均圈速 平均圈速 **BEST LAP** ベストラップ 最佳圈速 最佳圈速 **RACE TIME** レースタイム 完成時間 完成時間



Parts List-Standard Parts

Parts#	Description
TD210016	DIFF HOUSING SET
TD210017	DIFF GEAR & SHAFT SET
TD210018	DIFF OUTDRIVE SET (FRONT & REAR)
TD210019	DIFF OUTDRIVE SET (MID)
TD210020	FRONT DRIVESHAFT SET (1 PAIR)
TD210021	REAR DRIVESHAFT SET (1 PAIR)
TD210022	MID DRIVESHAFT SET (FRONT OR REAR)
TD210023	COMPLETE DIFF SET (FRONT OR REAR)
TD210024	COMPLETE DIFF SET (CENTRE)
TD210025	BRAKE SHAFT & LINK SET
TD210026	DIFF SEAL SET
TD210027	DRIVESHAFT COUPLING SET (FRONT OR REAR)
TD210028	WHEEL HEX SET (1 PAIR)
TD210029	BRAKE SCREW & SPRING SET
TD210030	DRIVESHAFT COUPLING SET (MID DRIVESHAFT)
TD220004	REAR STIFFENER MOUNTING SET
TD230015	FRONT SHOCK SET (1 PAIR)
TD230016	REAR SHOCK SET (1 PAIR)
TD230018	SHOCK O-RING SET (4 SHOCKS)
TD240002	SERVO HORN & STEERING PARTS SET
TD260003	HUB BEARING SET
TD260004	CENTRELINE TRANSMISSION BEARING SET
TD270002	CLUTCH AND FLYWHEEL FITTINGS SET
TD270003	FUEL TANK MOUNTING HARDWARE SET
TD270004	STEERING PLATE FITTINGS SET
TD290002	AIR FILTER SET
TD290003	THROTTLE & BRAKE LINK HARDWARE SET
TD290004	FUEL TANK SET
TD290005	AIR FILTER ELEMENT SET (4 pcs INNER & 4 pcs OUTER)
TD290006	EXHAUST MOUNTING SET (FRONT)
TD290007	FUEL TANK PARTS SET
TD290009	RECEIVER BOX RUBBER PARTS
TD310040	ENGINE MOUNT
TD310043	WHEEL NUT (4pcs)
TD310046	GEAR BEARING TUBE
TD310051	BRAKE DISK 32MM (2pcs)
TD310057	SHOCK BOOT FRONT (2pcs)
TD310058	SHOCK BOOT REAR (2pcs)
TD310059	CVD BOOT (4pcs)
TD310062	BRAKE PAD (4pcs)
TD310063	MID DRIVESHAFT (1pc)
TD310064	REAR DRIVESHAFT (1pc)
TD310065	WHEEL AXLE (1pc)
TD310066	FRONT DRIVESHAFT (1pc)
TD310070	BRAKE LINKAGE TIE ROD
TD310071	THROTTLE LINKAGE TIE ROD
TD310074	DIFF RING GEAR 43T (1pc)
TD310084	INPUT GEAR (1pc)
TD310087	WHEEL HEX PIN (10pcs)
TD310090	SPUR GEAR 48T (1M)
TD310092	MID SHAFT SNAP RING (10pcs)
TD310093	GEARBOX SET
TD310098	FUEL LINE (300mm)
TD310157	CLUTCH BELL 13T
TD310159	CLUTCH SPRING 1.0mm (3pcs)
TD310160	FLYWHEEL
TD310161	CLUTCH SHOE (3pcs)
TD320010	CHASSIS PLATE (5mm)
TD320011	FRONT BULKHEAD (RIGHT)
TD320012	REAR BULKHEAD (LEFT)
TD320014	REAR BULKHEAD (RIGHT)
TD320015	MID DRIVE HOLDER FRONT
TD320016	MID DRIVE HOLDER REAR
TD320017	MID GEAR PLATE
TD320018	RADIO PLATE
TD320019	ENGINE MOUNT MEMORY PLATE
TD320022	FRONT BULKHEAD (LEFT)
TD320027	PLASTIC CHASSIS STIFFENER SET
TD320028	BUMPER, BODY MOUNT & WING MOUNT SET
TD320030	SIDE & MUD GUARD SET
TD320031	FUEL TANK CAP SET
TD320032	RADIO BOX & GEAR GUARD SET
TD320091	REAR BRAKE BOLT GUIDE
TD330069	SUSPENSION MOUNT ALUMINIUM FF

Parts#	Description
TD330070	SUSPENSION MOUNT ALUMINIUM FR
TD330071	SUSPENSION MOUNT REAR LEFT
TD330072	SUSPENSION MOUNT RF
TD330073	PIVOT BALL A-TYPE
TD330074	ANTI-ROLL BAR BALL (4pcs)
TD330075	ANTI-ROLL BAR PIVOT BALL
TD330076	SUSPENSION ARM BUSHING (4pcs)
TD330078	SUSPENSION MOUNT REAR RIGHT
TD330079	REAR SUSPENSION PLATE
TD330080	SHOCK BODY ALUMINIUM FRONT
TD330081	SHOCK CAP ALUMINIUM
TD330082	SHOCK PRELOAD NUT & O-RING (PAIR)
TD330083	SHOCK SEAL CAP (1pc)
TD330084	SHOCK BODY ALUMINIUM REAR
TD330086	REAR SHOCK TOWER
TD330087	FRONT SHOCK TOWER
TD330088	SHOCK SPRINGS: REAR BLUE (2pcs)
TD330089	SHOCK SPRINGS: FRONT BLUE (2pcs)
TD330097	SHOCK DIAPHRAGM (4pcs)
TD330099	SHOCK SEAL O-RING (8pcs)
TD330100	PIVOT BALL G-TYPE
TD330101	SHOCK MOUNT (2pcs)
TD330102	TURNBUCKLE 64mm (2pcs)
TD330103	TURNBUCKLE 48mm (2pcs)
TD330104	HINGE PIN INNER 59mm (2pcs)
TD330105	HINGE PIN REAR OUTER (2pcs)
TD330106	KINGPIN (2pcs)
TD330107	TURNBUCKLE 60mm (2pcs)
TD330108	TURNBUCKLE 33mm (1pc)
TD330109	PIVOT BALL E-TYPE (2pcs)
TD330110	FRONT SHOCK SHAFT (2pcs)
TD330111	SHOCK PISTON WASHER (10pcs)
TD330112	REAR SHOCK SHAFT (2pcs)
TD330113	TURNBUCKLE 18mm (1pc)
TD330114	TURNBUCKLE 42mm (1pc)
TD330115	PIVOT BALL I-TYPE (2pcs)
TD330116	PIVOT BALL J-TYPE (2pcs)
TD330117	FRONT SUSPENSION ARMS
TD330118	REAR SUSPENSION ARMS
TD330119	STEERING KNUCKLES (LEFT & RIGHT)
TD330120	REAR HUB CARRIER SET (0 & 1 DEGREE)
TD330121	PLASTIC BALL ENDS
TD330122	PLASTIC SHOCK PARTS & SHIMS
TD330123	PLASTIC THROTTLE LINK & TRANSPONDER HOLDER
TD330131	C-HUBS 10 DEGREES (LEFT & RIGHT)
TD330132	C-HUBS 14 DEGREES (LEFT & RIGHT)
TD330133	SUSPENSION MOUNT INSERT SET
TD330204	ANTI-ROLL BAR FRONT 2.6mm
TD330209	ANTI-ROLL BAR REAR 2.6mm
TD340009	STEERING POST (1pc)
TD340010	SERVO SAVER NUT (1pc)
TD340011	STEERING PLATE
TD340012	STEERING ARM SPACER (2pcs)
TD340013	SERVO SAVER SHAFT
TD340015	SERVO SAVER SPRING
TD390001	ANTENNA TUBE & CAP (1pc)
TD390006	THREAD LOCK
TD390007	BODY CLIP (10pcs)
TD390014	ALLEN KEY SET (1.5, 2.0, 2.5, 3.0mm)
TD390016	CABLE TIE (10pcs)
TD390017	GEAR GREASE
TD390028	TURNBUCKLE WRENCH 4&5mm
TD402002	DNX408 CLEAR BODY SET
TD480002	REAR WING BLACK
TD490005	DNX408 DECAL SHEET
TD510006	WHEEL RIM WHITE (2pcs)
TD601002	BALL BEARING : 4PCS (5x10x4mm)
TD601003	BALL BEARING : 4PCS (10x15x4mm)
TD601004	BALL BEARING 6x10x3mm (4pcs)
TD601005	BALL BEARING 8x16x5mm (4pcs)
TD601007	BALL BEARING 12x18x4mm (4pcs)
TD602002	BALL BEARING FLANGED 4x7x2.5mm (2pcs)
TD602003	BALL BEARING FLANGED 8x14x4mm (2pcs)
TD701002	SETSCREW M3x4mm (10pcs)
TD701003	SETSCREW M3x5mm (10pcs)
TD701004	SETSCREW M3x3mm (10pcs)
TD701005	SETSCREW M3x10mm (10pcs)

Parts#	Description
--------	-------------

TD701009	SET SCREW M4x5mm (10pcs)
TD701012	SET SCREW M4x12mm (10pcs)
TD704003	FLAT HEAD HEX CS SCREW M3x12mm (10pcs)
TD704004	FLAT HEAD HEX CS SCREW M3x6mm (10pcs)
TD704006	FLAT HEAD HEX CS SCREW M3x8mm (10pcs)
TD704007	FLAT HEAD HEX CS SCREW M3x10mm (10pcs)
TD704009	CAP HEAD HEX SCREW M3x10mm (10pcs)
TD704010	FLAT HEAD HEX CS SCREW M2.5x5mm (10pcs)
TD704013	FLAT HEAD HEX CS SCREW M3x14mm (10pcs)
TD704014	FLAT HEAD HEX CS SCREW M3x20mm (10pcs)
TD704019	CAP HEAD HEX SCREW M2.5x6mm (10pcs)
TD704020	CAP HEAD HEX SCREW M2.5x8mm (10pcs)
TD704022	CAP HEAD HEX SCREW M3x12mm (10pcs)
TD704024	CAP HEAD HEX SCREW M3x16mm (10pcs)
TD704025	CAP HEAD HEX SCREW M3x40mm (10pcs)
TD704026	CAP HEAD HEX SCREW M3x5mm (10pcs)
TD704027	CAP HEAD HEX SCREW M3x6mm (10pcs)
TD704028	CAP HEAD HEX SCREW M3x8mm (10pcs)
TD704037	FLAT HEAD HEX CS SCREW M4x12mm (10pcs)
TD704046	FLAT HEAD HEX CS SCREW M2x5mm (10pcs)
TD705001	BUTTON HEAD HEX SCREW M3x6mm (10pcs)
TD705002	BUTTON HEAD HEX SCREW M3x8mm (10pcs)
TD705005	BUTTON HEAD HEX SCREW M3x10mm (10pcs)
TD705006	BUTTON HEAD HEX SCREW M3x5mm (10pcs)
TD705010	BUTTON HEAD HEX SCREW M3x25mm (10pcs)
TD705011	BUTTON HEAD HEX SCREW M3x14mm (10pcs)
TD705012	BUTTON HEAD HEX SCREW M3x18mm (10pcs)
TD705013	BUTTON HEAD HEX SCREW M3x22mm (10pcs)
TD705014	BUTTON HEAD HEX SCREW M3x20mm (10pcs)
TD705015	BUTTON HEAD HEX SCREW M3x16mm (10pcs)
TD705016	BUTTON HEAD HEX SCREW M2.5x8mm (10pcs)
TD705022	BUTTON HEAD HEX SCREW M4x18mm (10pcs)
TD709007	SERVO WASHER ALUMINIUM 6x3x0.5mm
TD709011	PIVOT BALL BUSHING (10pcs)
TD709015	DISTANCE SHIM 5x7x0.2 (10pcs)
TD709019	CLUTCH SHOE SHIM 2.6x6x0.5mm (3pcs)
TD709020	COUNTERSUNK WASHER M4 (4pcs)
TD709022	SHIM 8.0x10.0x0.1mm (10pcs)
TD709023	SHIM 13.0x16.0x0.1mm (10pcs)
TD712002	PIVOT BALL BUSHING : CONICAL 7x3x2mm (10pcs)
TD715002	LOCKNUT M3: STANDARD (10PCS)

Parts List-Option Parts

Parts#	Description
TD230014	ANTI-ROLL BAR TUNING SET FRONT
TD230019	SPRING TUNING SET FRONT (8 PAIRS)
TD230020	SPRING TUNING SET REAR (8 PAIRS)
TD230021	ANTI-ROLL BAR TUNING SET REAR
TD290008	EXHAUST SUPPORT SET (MANIFOLD)
TD310158	CLUTCH BELL 14T
TD320034	ALUMINIUM FRONT STIFFENER
TD320037	ALUMINIUM REAR STIFFENER
TD320038	CARBON FIBRE MID GEAR PLATE
TD320039	CARBON FIBRE RADIO PLATE
TD330085	SHOCK MOUNT SHIM ALUMINIUM (4pcs)
TD330182	PIVOT BALL A-TYPE ALUMINIUM (2pcs)
TD330183	PIVOT BALL C-TYPE ALUMINIUM (2pcs)
TD330184	CARBON FIBRE SHOCK TOWER FRONT
TD330185	CARBON FIBRE SHOCK TOWER REAR
TD330186	SHOCK MOUNT TITANIUM (2pcs)
TD330187	SHOCK SPRINGS: FRONT BLACK (2pcs)
TD330188	SHOCK SPRINGS: FRONT GREY (2pcs)
TD330189	SHOCK SPRINGS: FRONT GREEN (2pcs)
TD330190	SHOCK SPRINGS: FRONT ORANGE (2pcs)
TD330191	SHOCK SPRINGS: FRONT RED (2pcs)
TD330192	SHOCK SPRINGS: FRONT YELLOW (2pcs)
TD330193	SHOCK SPRINGS: FRONT WHITE (2pcs)
TD330194	SHOCK SPRINGS: REAR BLACK (2pcs)
TD330195	SHOCK SPRINGS: REAR GREY (2pcs)
TD330196	SHOCK SPRINGS: REAR GREEN (2pcs)
TD330197	SHOCK SPRINGS: REAR ORANGE (2pcs)
TD330198	SHOCK SPRINGS: REAR RED (2pcs)
TD330199	SHOCK SPRINGS: REAR YELLOW (2pcs)
TD330200	SHOCK SPRINGS: REAR WHITE (2pcs)
TD330201	ANTI-ROLL BAR FRONT 2.0mm
TD330202	ANTI-ROLL BAR FRONT 2.2mm
TD330203	ANTI-ROLL BAR FRONT 2.4mm
TD330205	ANTI-ROLL BAR FRONT 2.8mm
TD330206	ANTI-ROLL BAR REAR 2.0mm
TD330207	ANTI-ROLL BAR REAR 2.2mm
TD330208	ANTI-ROLL BAR REAR 2.4mm
TD330210	ANTI-ROLL BAR REAR 2.8mm
TD340014	SERVO SAVER ARM ALUMINIUM
TD340017	ALUMINIUM SERVO MOUNT SET (STEERING SERVO)
TD340018	ALUMINIUM SERVO MOUNT SET (THROTTLE SERVO)
TD340026	SUSPENSION ARM BUSHING ALUMINIUM (4pcs)
TD510008	WHEEL RIM YELLOW(2pcs)

Team Durango Ltd

Team Durango Ltd is registered in Derbyshire, England, UK

Internet:

www.team-durango.com
support@team-durango.com

The contents of this owner's manual and all associated material are copyright © Team Durango Ltd. No part of this owner's manual or associated material may be reproduced or distributed in any medium or media without the express, written permission of Team Durango Ltd.

Team Durango Ltd

Team Durango Ltd is in Derbyshire, England, Großbritannien registriert

Internet:

www.team-durango.com
support@team-durango.com

Der Inhalt dieser Bauanleitung und alles dazugehörige Material unterstehen dem Copyright Team Durango Ltd.

Kein Teil dieser Bauanleitung, oder dazugehöriges Material darf weder kopiert, oder in jegliches Medium vertrieben werden, ohne die schriftliche Zustimmung von Team Durango Ltd.

Team Durango Ltd

Team Durango Ltd 登記住所 : Derbyshire, England, UK

ウェブサイト:

www.team-durango.com
support@team-durango.com

本書の内容は著作権法により保護されています。

本書の内容の一部または全部をTeam Durango Ltdによる

書面の許可無しに無断転載する事を禁止します。

Team Durango 連絡情報

Team Durango的联络地址: Derbyshire, England, UK

网络信息:

www.team-durango.com
support@team-durango.com

本说明书与其相关信息内容, 其所有权由Team Durango所有。未经Team Durango许可, 禁止以任何形式转载

